

# Local convergence in t-PNG

joint with Ruby Bestwick, Artem Borisov, Elnur Emrah, and  
Jessica Jay

Márton Balázs

University of Bristol

Stochastics Seminar  
Universität Hamburg  
9<sup>th</sup> June 2026.

## Polynuclear Growth

*t*-PNG

Stationary *t*-PNG

Local convergence

Ingredients

Proof

# Polynuclear Growth (PNG) [Hammersley '72]

- ▶ Poisson space-time points initiate nucleations
-

# Polynuclear Growth (PNG) [Hammersley '72]

- ▶ Poisson space-time points initiate nucleations
  - ▶ Nucleations spread at unit speed
-

# Polynuclear Growth (PNG) [Hammersley '72]

- ▶ Poisson space-time points initiate nucleations
  - ▶ Nucleations spread at unit speed
  - ▶ They annihilate upon meeting
-

# Polynuclear Growth (PNG) [Hammersley '72]

- ▶ Poisson space-time points initiate nucleations
  - ▶ Nucleations spread at unit speed
  - ▶ They annihilate upon meeting
  - ▶  $\rightsquigarrow$  height function
-

# Polynuclear Growth (PNG) [Hammersley '72]

- ▶ Poisson space-time points initiate nucleations
  - ▶ Nucleations spread at unit speed
  - ▶ They annihilate upon meeting
  - ▶  $\rightsquigarrow$  height function
-

# Polynuclear Growth (PNG) [Hammersley '72]

- ▶ Poisson space-time points initiate nucleations
  - ▶ Nucleations spread at unit speed
  - ▶ They annihilate upon meeting
  - ▶  $\rightsquigarrow$  height function
-

# Polynuclear Growth (PNG) [Hammersley '72]

- ▶ Poisson space-time points initiate nucleations
  - ▶ Nucleations spread at unit speed
  - ▶ They annihilate upon meeting
  - ▶  $\rightsquigarrow$  height function
-

# Polynuclear Growth (PNG) [Hammersley '72]

- ▶ Poisson space-time points initiate nucleations
  - ▶ Nucleations spread at unit speed
  - ▶ They annihilate upon meeting
  - ▶  $\rightsquigarrow$  height function
-

# Polynuclear Growth (PNG) [Hammersley '72]

- ▶ Poisson space-time points initiate nucleations
  - ▶ Nucleations spread at unit speed
  - ▶ They annihilate upon meeting
  - ▶  $\rightsquigarrow$  height function
-

# Polynuclear Growth (PNG) [Hammersley '72]

- ▶ Poisson space-time points initiate nucleations
  - ▶ Nucleations spread at unit speed
  - ▶ They annihilate upon meeting
  - ▶  $\rightsquigarrow$  height function
-

# Polynuclear Growth (PNG) [Hammersley '72]

- ▶ Poisson space-time points initiate nucleations
  - ▶ Nucleations spread at unit speed
  - ▶ They annihilate upon meeting
  - ▶  $\rightsquigarrow$  height function
-

# Polynuclear Growth (PNG) [Hammersley '72]

- ▶ Poisson space-time points initiate nucleations
  - ▶ Nucleations spread at unit speed
  - ▶ They annihilate upon meeting
  - ▶  $\rightsquigarrow$  height function
-

# Polynuclear Growth (PNG) [Hammersley '72]

- ▶ Poisson space-time points initiate nucleations
  - ▶ Nucleations spread at unit speed
  - ▶ They annihilate upon meeting
  - ▶  $\rightsquigarrow$  height function
-

# Polynuclear Growth (PNG) [Hammersley '72]

- ▶ Poisson space-time points initiate nucleations
  - ▶ Nucleations spread at unit speed
  - ▶ They annihilate upon meeting
  - ▶  $\rightsquigarrow$  height function
-

# Polynuclear Growth (PNG) [Hammersley '72]

- ▶ Poisson space-time points initiate nucleations
  - ▶ Nucleations spread at unit speed
  - ▶ They annihilate upon meeting
  - ▶  $\rightsquigarrow$  height function
-

# Polynuclear Growth (PNG) [Hammersley '72]

- ▶ Poisson space-time points initiate nucleations
  - ▶ Nucleations spread at unit speed
  - ▶ They annihilate upon meeting
  - ▶  $\rightsquigarrow$  height function
-

# Polynuclear Growth (PNG) [Hammersley '72]

- ▶ Poisson space-time points initiate nucleations
- ▶ Nucleations spread at unit speed
- ▶ They annihilate upon meeting
- ▶  $\rightsquigarrow$  height function

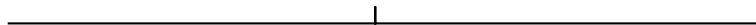

# Polynuclear Growth (PNG) [Hammersley '72]

- ▶ Poisson space-time points initiate nucleations
- ▶ Nucleations spread at unit speed
- ▶ They annihilate upon meeting
- ▶  $\rightsquigarrow$  height function



# Polynuclear Growth (PNG) [Hammersley '72]

- ▶ Poisson space-time points initiate nucleations
- ▶ Nucleations spread at unit speed
- ▶ They annihilate upon meeting
- ▶  $\rightsquigarrow$  height function



# Polynuclear Growth (PNG) [Hammersley '72]

- ▶ Poisson space-time points initiate nucleations
- ▶ Nucleations spread at unit speed
- ▶ They annihilate upon meeting
- ▶  $\rightsquigarrow$  height function



# Polynuclear Growth (PNG) [Hammersley '72]

- ▶ Poisson space-time points initiate nucleations
- ▶ Nucleations spread at unit speed
- ▶ They annihilate upon meeting
- ▶  $\rightsquigarrow$  height function



# Polynuclear Growth (PNG) [Hammersley '72]

- ▶ Poisson space-time points initiate nucleations
- ▶ Nucleations spread at unit speed
- ▶ They annihilate upon meeting
- ▶  $\rightsquigarrow$  height function

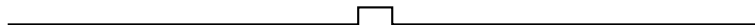

# Polynuclear Growth (PNG) [Hammersley '72]

- ▶ Poisson space-time points initiate nucleations
- ▶ Nucleations spread at unit speed
- ▶ They annihilate upon meeting
- ▶  $\rightsquigarrow$  height function

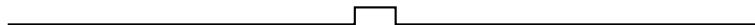

# Polynuclear Growth (PNG) [Hammersley '72]

- ▶ Poisson space-time points initiate nucleations
- ▶ Nucleations spread at unit speed
- ▶ They annihilate upon meeting
- ▶  $\rightsquigarrow$  height function

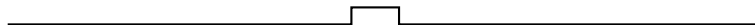

# Polynuclear Growth (PNG) [Hammersley '72]

- ▶ Poisson space-time points initiate nucleations
- ▶ Nucleations spread at unit speed
- ▶ They annihilate upon meeting
- ▶  $\rightsquigarrow$  height function

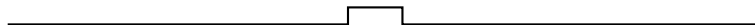

# Polynuclear Growth (PNG) [Hammersley '72]

- ▶ Poisson space-time points initiate nucleations
- ▶ Nucleations spread at unit speed
- ▶ They annihilate upon meeting
- ▶  $\rightsquigarrow$  height function

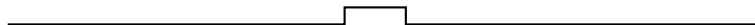

# Polynuclear Growth (PNG) [Hammersley '72]

- ▶ Poisson space-time points initiate nucleations
- ▶ Nucleations spread at unit speed
- ▶ They annihilate upon meeting
- ▶  $\rightsquigarrow$  height function

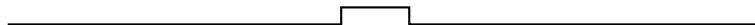

# Polynuclear Growth (PNG) [Hammersley '72]

- ▶ Poisson space-time points initiate nucleations
- ▶ Nucleations spread at unit speed
- ▶ They annihilate upon meeting
- ▶  $\rightsquigarrow$  height function



# Polynuclear Growth (PNG) [Hammersley '72]

- ▶ Poisson space-time points initiate nucleations
- ▶ Nucleations spread at unit speed
- ▶ They annihilate upon meeting
- ▶  $\rightsquigarrow$  height function

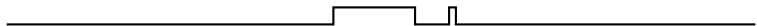

# Polynuclear Growth (PNG) [Hammersley '72]

- ▶ Poisson space-time points initiate nucleations
- ▶ Nucleations spread at unit speed
- ▶ They annihilate upon meeting
- ▶  $\rightsquigarrow$  height function

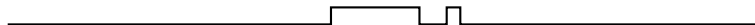

# Polynuclear Growth (PNG) [Hammersley '72]

- ▶ Poisson space-time points initiate nucleations
- ▶ Nucleations spread at unit speed
- ▶ They annihilate upon meeting
- ▶  $\rightsquigarrow$  height function

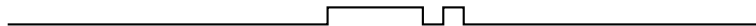

# Polynuclear Growth (PNG) [Hammersley '72]

- ▶ Poisson space-time points initiate nucleations
- ▶ Nucleations spread at unit speed
- ▶ They annihilate upon meeting
- ▶  $\rightsquigarrow$  height function

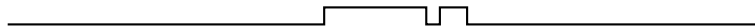

# Polynuclear Growth (PNG) [Hammersley '72]

- ▶ Poisson space-time points initiate nucleations
- ▶ Nucleations spread at unit speed
- ▶ They annihilate upon meeting
- ▶  $\rightsquigarrow$  height function

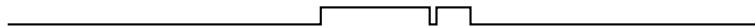

# Polynuclear Growth (PNG) [Hammersley '72]

- ▶ Poisson space-time points initiate nucleations
- ▶ Nucleations spread at unit speed
- ▶ They annihilate upon meeting
- ▶  $\rightsquigarrow$  height function

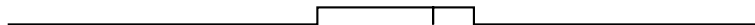

# Polynuclear Growth (PNG) [Hammersley '72]

- ▶ Poisson space-time points initiate nucleations
- ▶ Nucleations spread at unit speed
- ▶ They annihilate upon meeting
- ▶  $\rightsquigarrow$  height function

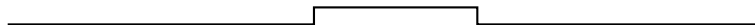

# Polynuclear Growth (PNG) [Hammersley '72]

- ▶ Poisson space-time points initiate nucleations
- ▶ Nucleations spread at unit speed
- ▶ They annihilate upon meeting
- ▶  $\rightsquigarrow$  height function

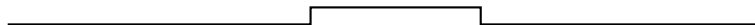

# Polynuclear Growth (PNG) [Hammersley '72]

- ▶ Poisson space-time points initiate nucleations
- ▶ Nucleations spread at unit speed
- ▶ They annihilate upon meeting
- ▶  $\rightsquigarrow$  height function

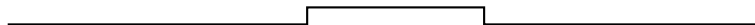

# Polynuclear Growth (PNG) [Hammersley '72]

- ▶ Poisson space-time points initiate nucleations
- ▶ Nucleations spread at unit speed
- ▶ They annihilate upon meeting
- ▶  $\rightsquigarrow$  height function

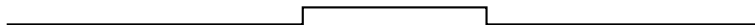

# Polynuclear Growth (PNG) [Hammersley '72]

- ▶ Poisson space-time points initiate nucleations
- ▶ Nucleations spread at unit speed
- ▶ They annihilate upon meeting
- ▶  $\rightsquigarrow$  height function

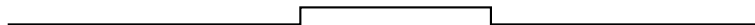

# Polynuclear Growth (PNG) [Hammersley '72]

- ▶ Poisson space-time points initiate nucleations
- ▶ Nucleations spread at unit speed
- ▶ They annihilate upon meeting
- ▶  $\rightsquigarrow$  height function

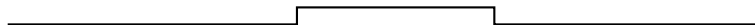

# Polynuclear Growth (PNG) [Hammersley '72]

- ▶ Poisson space-time points initiate nucleations
- ▶ Nucleations spread at unit speed
- ▶ They annihilate upon meeting
- ▶  $\rightsquigarrow$  height function

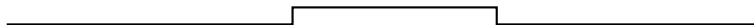

# Polynuclear Growth (PNG) [Hammersley '72]

- ▶ Poisson space-time points initiate nucleations
- ▶ Nucleations spread at unit speed
- ▶ They annihilate upon meeting
- ▶  $\rightsquigarrow$  height function

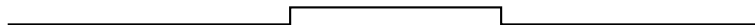

# Polynuclear Growth (PNG) [Hammersley '72]

- ▶ Poisson space-time points initiate nucleations
- ▶ Nucleations spread at unit speed
- ▶ They annihilate upon meeting
- ▶  $\rightsquigarrow$  height function

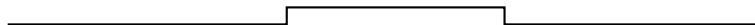

# Polynuclear Growth (PNG) [Hammersley '72]

- ▶ Poisson space-time points initiate nucleations
- ▶ Nucleations spread at unit speed
- ▶ They annihilate upon meeting
- ▶  $\rightsquigarrow$  height function

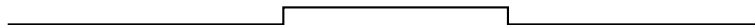

# Polynuclear Growth (PNG) [Hammersley '72]

- ▶ Poisson space-time points initiate nucleations
- ▶ Nucleations spread at unit speed
- ▶ They annihilate upon meeting
- ▶  $\rightsquigarrow$  height function

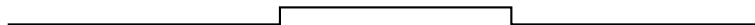

# Polynuclear Growth (PNG) [Hammersley '72]

- ▶ Poisson space-time points initiate nucleations
- ▶ Nucleations spread at unit speed
- ▶ They annihilate upon meeting
- ▶  $\rightsquigarrow$  height function

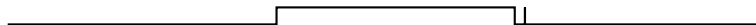

# Polynuclear Growth (PNG) [Hammersley '72]

- ▶ Poisson space-time points initiate nucleations
- ▶ Nucleations spread at unit speed
- ▶ They annihilate upon meeting
- ▶  $\rightsquigarrow$  height function

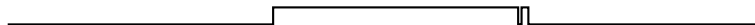

# Polynuclear Growth (PNG) [Hammersley '72]

- ▶ Poisson space-time points initiate nucleations
- ▶ Nucleations spread at unit speed
- ▶ They annihilate upon meeting
- ▶  $\rightsquigarrow$  height function

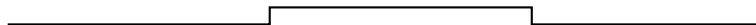

# Polynuclear Growth (PNG) [Hammersley '72]

- ▶ Poisson space-time points initiate nucleations
- ▶ Nucleations spread at unit speed
- ▶ They annihilate upon meeting
- ▶  $\rightsquigarrow$  height function

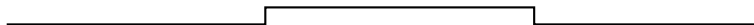

# Polynuclear Growth (PNG) [Hammersley '72]

- ▶ Poisson space-time points initiate nucleations
- ▶ Nucleations spread at unit speed
- ▶ They annihilate upon meeting
- ▶  $\rightsquigarrow$  height function

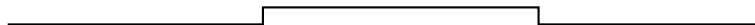

# Polynuclear Growth (PNG) [Hammersley '72]

- ▶ Poisson space-time points initiate nucleations
- ▶ Nucleations spread at unit speed
- ▶ They annihilate upon meeting
- ▶  $\rightsquigarrow$  height function

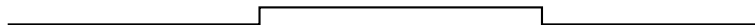

# Polynuclear Growth (PNG) [Hammersley '72]

- ▶ Poisson space-time points initiate nucleations
- ▶ Nucleations spread at unit speed
- ▶ They annihilate upon meeting
- ▶  $\rightsquigarrow$  height function

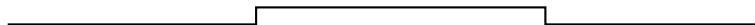

# Polynuclear Growth (PNG) [Hammersley '72]

- ▶ Poisson space-time points initiate nucleations
- ▶ Nucleations spread at unit speed
- ▶ They annihilate upon meeting
- ▶  $\rightsquigarrow$  height function

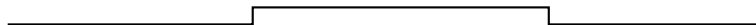

# Polynuclear Growth (PNG) [Hammersley '72]

- ▶ Poisson space-time points initiate nucleations
- ▶ Nucleations spread at unit speed
- ▶ They annihilate upon meeting
- ▶  $\rightsquigarrow$  height function

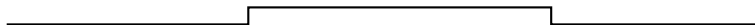

# Polynuclear Growth (PNG) [Hammersley '72]

- ▶ Poisson space-time points initiate nucleations
- ▶ Nucleations spread at unit speed
- ▶ They annihilate upon meeting
- ▶  $\rightsquigarrow$  height function

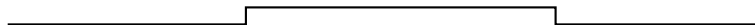

# Polynuclear Growth (PNG) [Hammersley '72]

- ▶ Poisson space-time points initiate nucleations
- ▶ Nucleations spread at unit speed
- ▶ They annihilate upon meeting
- ▶  $\rightsquigarrow$  height function

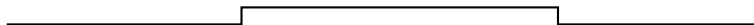

# Polynuclear Growth (PNG) [Hammersley '72]

- ▶ Poisson space-time points initiate nucleations
- ▶ Nucleations spread at unit speed
- ▶ They annihilate upon meeting
- ▶  $\rightsquigarrow$  height function

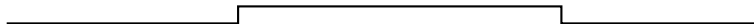

# Polynuclear Growth (PNG) [Hammersley '72]

- ▶ Poisson space-time points initiate nucleations
- ▶ Nucleations spread at unit speed
- ▶ They annihilate upon meeting
- ▶  $\rightsquigarrow$  height function

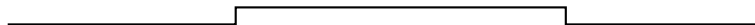

# Polynuclear Growth (PNG) [Hammersley '72]

- ▶ Poisson space-time points initiate nucleations
- ▶ Nucleations spread at unit speed
- ▶ They annihilate upon meeting
- ▶  $\rightsquigarrow$  height function

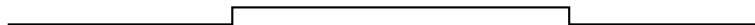

# Polynuclear Growth (PNG) [Hammersley '72]

- ▶ Poisson space-time points initiate nucleations
- ▶ Nucleations spread at unit speed
- ▶ They annihilate upon meeting
- ▶  $\rightsquigarrow$  height function

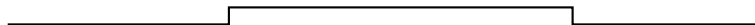

# Polynuclear Growth (PNG) [Hammersley '72]

- ▶ Poisson space-time points initiate nucleations
- ▶ Nucleations spread at unit speed
- ▶ They annihilate upon meeting
- ▶  $\rightsquigarrow$  height function

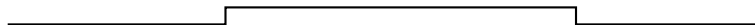

# Polynuclear Growth (PNG) [Hammersley '72]

- ▶ Poisson space-time points initiate nucleations
- ▶ Nucleations spread at unit speed
- ▶ They annihilate upon meeting
- ▶  $\rightsquigarrow$  height function

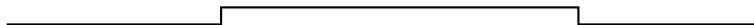

# Polynuclear Growth (PNG) [Hammersley '72]

- ▶ Poisson space-time points initiate nucleations
- ▶ Nucleations spread at unit speed
- ▶ They annihilate upon meeting
- ▶  $\rightsquigarrow$  height function

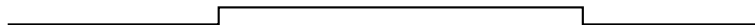

# Polynuclear Growth (PNG) [Hammersley '72]

- ▶ Poisson space-time points initiate nucleations
- ▶ Nucleations spread at unit speed
- ▶ They annihilate upon meeting
- ▶  $\rightsquigarrow$  height function

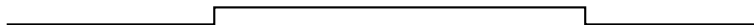

# Polynuclear Growth (PNG) [Hammersley '72]

- ▶ Poisson space-time points initiate nucleations
- ▶ Nucleations spread at unit speed
- ▶ They annihilate upon meeting
- ▶  $\rightsquigarrow$  height function

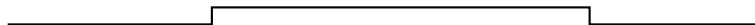

# Polynuclear Growth (PNG) [Hammersley '72]

- ▶ Poisson space-time points initiate nucleations
- ▶ Nucleations spread at unit speed
- ▶ They annihilate upon meeting
- ▶  $\rightsquigarrow$  height function

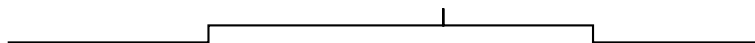

# Polynuclear Growth (PNG) [Hammersley '72]

- ▶ Poisson space-time points initiate nucleations
- ▶ Nucleations spread at unit speed
- ▶ They annihilate upon meeting
- ▶  $\rightsquigarrow$  height function

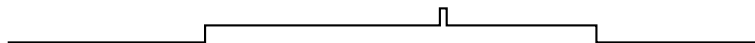

# Polynuclear Growth (PNG) [Hammersley '72]

- ▶ Poisson space-time points initiate nucleations
- ▶ Nucleations spread at unit speed
- ▶ They annihilate upon meeting
- ▶  $\rightsquigarrow$  height function

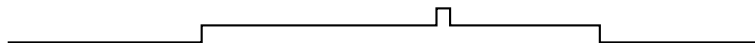

# Polynuclear Growth (PNG) [Hammersley '72]

- ▶ Poisson space-time points initiate nucleations
- ▶ Nucleations spread at unit speed
- ▶ They annihilate upon meeting
- ▶  $\rightsquigarrow$  height function

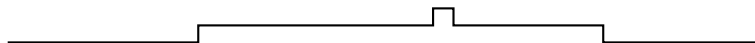

# Polynuclear Growth (PNG) [Hammersley '72]

- ▶ Poisson space-time points initiate nucleations
- ▶ Nucleations spread at unit speed
- ▶ They annihilate upon meeting
- ▶  $\rightsquigarrow$  height function

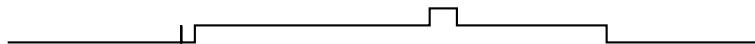

# Polynuclear Growth (PNG) [Hammersley '72]

- ▶ Poisson space-time points initiate nucleations
- ▶ Nucleations spread at unit speed
- ▶ They annihilate upon meeting
- ▶  $\rightsquigarrow$  height function

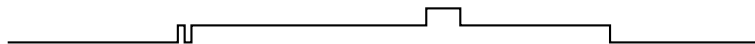

# Polynuclear Growth (PNG) [Hammersley '72]

- ▶ Poisson space-time points initiate nucleations
- ▶ Nucleations spread at unit speed
- ▶ They annihilate upon meeting
- ▶  $\rightsquigarrow$  height function

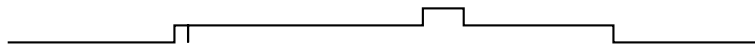

# Polynuclear Growth (PNG) [Hammersley '72]

- ▶ Poisson space-time points initiate nucleations
- ▶ Nucleations spread at unit speed
- ▶ They annihilate upon meeting
- ▶  $\rightsquigarrow$  height function

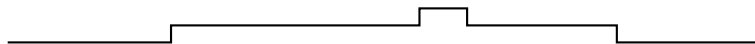

# Polynuclear Growth (PNG) [Hammersley '72]

- ▶ Poisson space-time points initiate nucleations
- ▶ Nucleations spread at unit speed
- ▶ They annihilate upon meeting
- ▶  $\rightsquigarrow$  height function

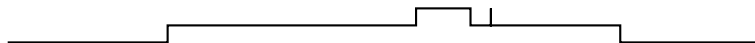

# Polynuclear Growth (PNG) [Hammersley '72]

- ▶ Poisson space-time points initiate nucleations
- ▶ Nucleations spread at unit speed
- ▶ They annihilate upon meeting
- ▶  $\rightsquigarrow$  height function

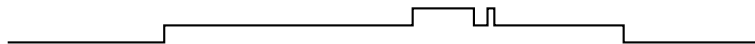

# Polynuclear Growth (PNG) [Hammersley '72]

- ▶ Poisson space-time points initiate nucleations
- ▶ Nucleations spread at unit speed
- ▶ They annihilate upon meeting
- ▶  $\rightsquigarrow$  height function

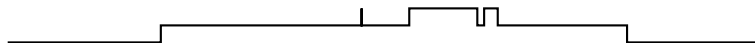

# Polynuclear Growth (PNG) [Hammersley '72]

- ▶ Poisson space-time points initiate nucleations
- ▶ Nucleations spread at unit speed
- ▶ They annihilate upon meeting
- ▶  $\rightsquigarrow$  height function

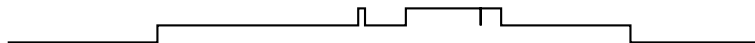

# Polynuclear Growth (PNG) [Hammersley '72]

- ▶ Poisson space-time points initiate nucleations
- ▶ Nucleations spread at unit speed
- ▶ They annihilate upon meeting
- ▶  $\rightsquigarrow$  height function

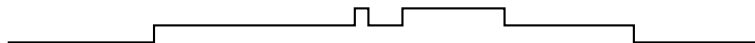

# Polynuclear Growth (PNG) [Hammersley '72]

- ▶ Poisson space-time points initiate nucleations
- ▶ Nucleations spread at unit speed
- ▶ They annihilate upon meeting
- ▶  $\rightsquigarrow$  height function



# Polynuclear Growth (PNG) [Hammersley '72]

- ▶ Poisson space-time points initiate nucleations
- ▶ Nucleations spread at unit speed
- ▶ They annihilate upon meeting
- ▶  $\rightsquigarrow$  height function



# Polynuclear Growth (PNG) [Hammersley '72]

- ▶ Poisson space-time points initiate nucleations
- ▶ Nucleations spread at unit speed
- ▶ They annihilate upon meeting
- ▶  $\rightsquigarrow$  height function

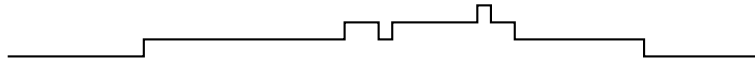

# Polynuclear Growth (PNG) [Hammersley '72]

- ▶ Poisson space-time points initiate nucleations
- ▶ Nucleations spread at unit speed
- ▶ They annihilate upon meeting
- ▶  $\rightsquigarrow$  height function

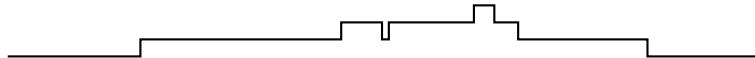

# Polynuclear Growth (PNG) [Hammersley '72]

- ▶ Poisson space-time points initiate nucleations
- ▶ Nucleations spread at unit speed
- ▶ They annihilate upon meeting
- ▶  $\rightsquigarrow$  height function

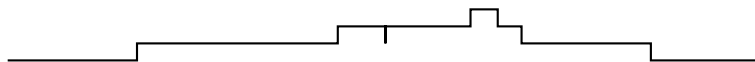

# Polynuclear Growth (PNG) [Hammersley '72]

- ▶ Poisson space-time points initiate nucleations
- ▶ Nucleations spread at unit speed
- ▶ They annihilate upon meeting
- ▶  $\rightsquigarrow$  height function

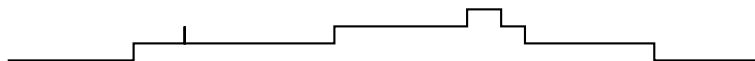

# Polynuclear Growth (PNG) [Hammersley '72]

- ▶ Poisson space-time points initiate nucleations
- ▶ Nucleations spread at unit speed
- ▶ They annihilate upon meeting
- ▶  $\rightsquigarrow$  height function

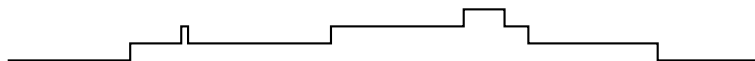

# Polynuclear Growth (PNG) [Hammersley '72]

- ▶ Poisson space-time points initiate nucleations
- ▶ Nucleations spread at unit speed
- ▶ They annihilate upon meeting
- ▶  $\rightsquigarrow$  height function

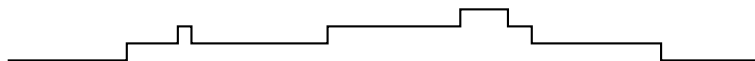

# Polynuclear Growth (PNG) [Hammersley '72]

- ▶ Poisson space-time points initiate nucleations
- ▶ Nucleations spread at unit speed
- ▶ They annihilate upon meeting
- ▶  $\rightsquigarrow$  height function

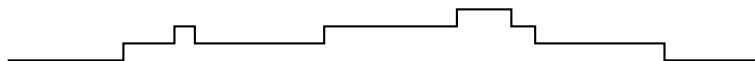

# Polynuclear Growth (PNG) [Hammersley '72]

- ▶ Poisson space-time points initiate nucleations
- ▶ Nucleations spread at unit speed
- ▶ They annihilate upon meeting
- ▶  $\rightsquigarrow$  height function

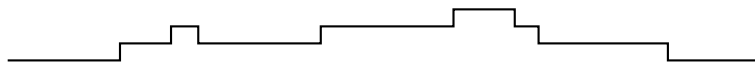

# Polynuclear Growth (PNG) [Hammersley '72]

- ▶ Poisson space-time points initiate nucleations
- ▶ Nucleations spread at unit speed
- ▶ They annihilate upon meeting
- ▶  $\rightsquigarrow$  height function

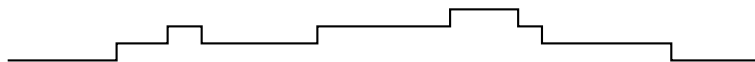

# Polynuclear Growth (PNG) [Hammersley '72]

- ▶ Poisson space-time points initiate nucleations
- ▶ Nucleations spread at unit speed
- ▶ They annihilate upon meeting
- ▶  $\rightsquigarrow$  height function

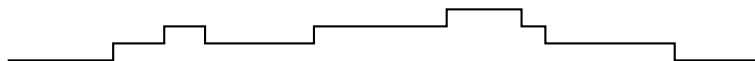

# Polynuclear Growth (PNG) [Hammersley '72]

- ▶ Poisson space-time points initiate nucleations
- ▶ Nucleations spread at unit speed
- ▶ They annihilate upon meeting
- ▶  $\rightsquigarrow$  height function

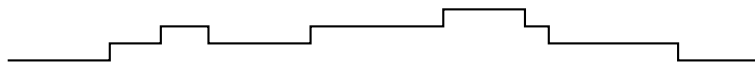

# Polynuclear Growth (PNG) [Hammersley '72]

- ▶ Poisson space-time points initiate nucleations
- ▶ Nucleations spread at unit speed
- ▶ They annihilate upon meeting
- ▶  $\rightsquigarrow$  height function

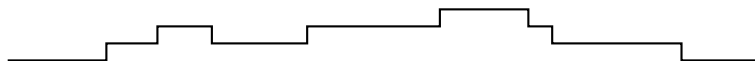

# Polynuclear Growth (PNG) [Hammersley '72]

- ▶ Poisson space-time points initiate nucleations
- ▶ Nucleations spread at unit speed
- ▶ They annihilate upon meeting
- ▶  $\rightsquigarrow$  height function

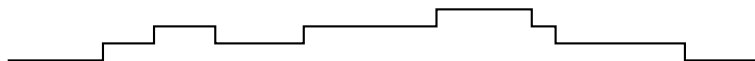

# Polynuclear Growth (PNG) [Hammersley '72]

- ▶ Poisson space-time points initiate nucleations
- ▶ Nucleations spread at unit speed
- ▶ They annihilate upon meeting
- ▶  $\rightsquigarrow$  height function

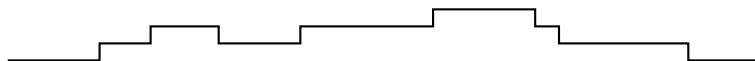

# Polynuclear Growth (PNG) [Hammersley '72]

- ▶ Poisson space-time points initiate nucleations
- ▶ Nucleations spread at unit speed
- ▶ They annihilate upon meeting
- ▶  $\rightsquigarrow$  height function

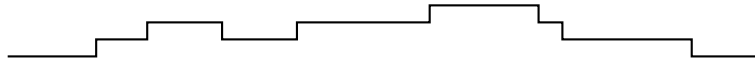

# Polynuclear Growth (PNG) [Hammersley '72]

- ▶ Poisson space-time points initiate nucleations
- ▶ Nucleations spread at unit speed
- ▶ They annihilate upon meeting
- ▶  $\rightsquigarrow$  height function

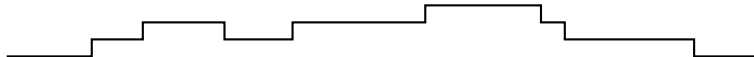

# Polynuclear Growth (PNG) [Hammersley '72]

- ▶ Poisson space-time points initiate nucleations
- ▶ Nucleations spread at unit speed
- ▶ They annihilate upon meeting
- ▶  $\rightsquigarrow$  height function

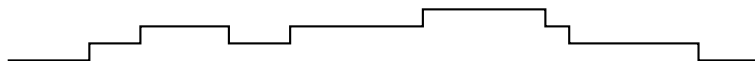

# Polynuclear Growth (PNG) [Hammersley '72]

- ▶ Poisson space-time points initiate nucleations
- ▶ Nucleations spread at unit speed
- ▶ They annihilate upon meeting
- ▶  $\rightsquigarrow$  height function

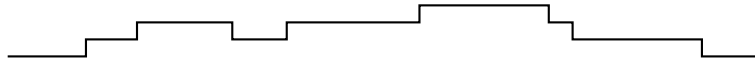

# Polynuclear Growth (PNG) [Hammersley '72]

- ▶ Poisson space-time points initiate nucleations
- ▶ Nucleations spread at unit speed
- ▶ They annihilate upon meeting
- ▶  $\rightsquigarrow$  height function

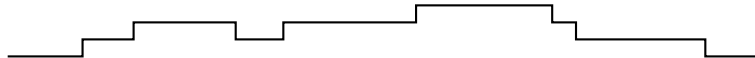

# Polynuclear Growth (PNG) [Hammersley '72]

- ▶ Poisson space-time points initiate nucleations
- ▶ Nucleations spread at unit speed
- ▶ They annihilate upon meeting
- ▶  $\rightsquigarrow$  height function

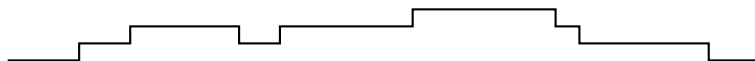

# Polynuclear Growth (PNG) [Hammersley '72]

- ▶ Poisson space-time points initiate nucleations
- ▶ Nucleations spread at unit speed
- ▶ They annihilate upon meeting
- ▶  $\rightsquigarrow$  height function

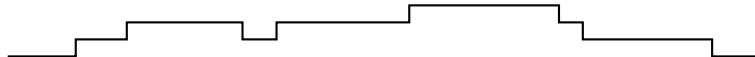

# Polynuclear Growth (PNG) [Hammersley '72]

- ▶ Poisson space-time points initiate nucleations
- ▶ Nucleations spread at unit speed
- ▶ They annihilate upon meeting
- ▶  $\rightsquigarrow$  height function

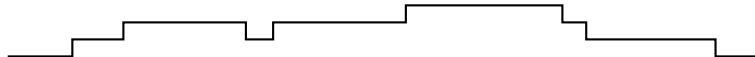

# Polynuclear Growth (PNG) [Hammersley '72]

- ▶ Poisson space-time points initiate nucleations
- ▶ Nucleations spread at unit speed
- ▶ They annihilate upon meeting
- ▶  $\rightsquigarrow$  height function

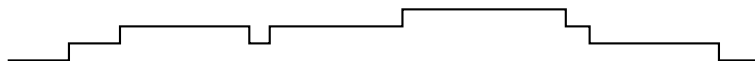

# Polynuclear Growth (PNG) [Hammersley '72]

- ▶ Poisson space-time points initiate nucleations
- ▶ Nucleations spread at unit speed
- ▶ They annihilate upon meeting
- ▶  $\rightsquigarrow$  height function

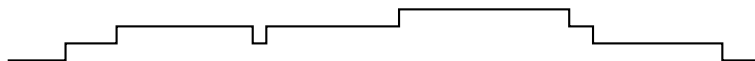

# Polynuclear Growth (PNG) [Hammersley '72]

- ▶ Poisson space-time points initiate nucleations
- ▶ Nucleations spread at unit speed
- ▶ They annihilate upon meeting
- ▶  $\rightsquigarrow$  height function

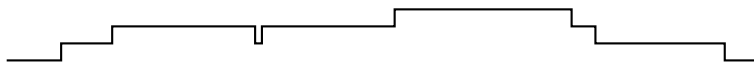

# Polynuclear Growth (PNG) [Hammersley '72]

- ▶ Poisson space-time points initiate nucleations
- ▶ Nucleations spread at unit speed
- ▶ They annihilate upon meeting
- ▶  $\rightsquigarrow$  height function

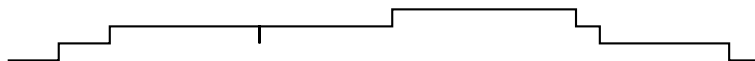

# Polynuclear Growth (PNG) [Hammersley '72]

- ▶ Poisson space-time points initiate nucleations
- ▶ Nucleations spread at unit speed
- ▶ They annihilate upon meeting
- ▶  $\rightsquigarrow$  height function

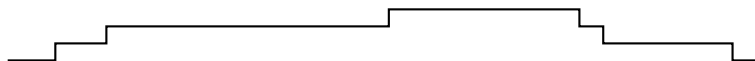

# Polynuclear Growth (PNG) [Hammersley '72]

- ▶ Poisson space-time points initiate nucleations
- ▶ Nucleations spread at unit speed
- ▶ They annihilate upon meeting
- ▶  $\rightsquigarrow$  height function

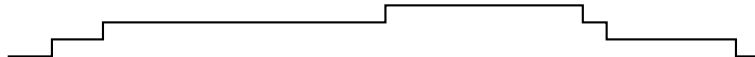

# Polynuclear Growth (PNG) [Hammersley '72]

- ▶ Poisson space-time points initiate nucleations
- ▶ Nucleations spread at unit speed
- ▶ They annihilate upon meeting
- ▶  $\rightsquigarrow$  height function

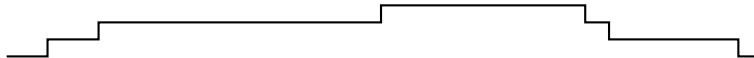

# Polynuclear Growth (PNG) [Hammersley '72]

- ▶ Poisson space-time points initiate nucleations
- ▶ Nucleations spread at unit speed
- ▶ They annihilate upon meeting
- ▶  $\rightsquigarrow$  height function

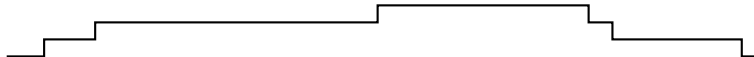

# Polynuclear Growth (PNG) [Hammersley '72]

- ▶ Poisson space-time points initiate nucleations
- ▶ Nucleations spread at unit speed
- ▶ They annihilate upon meeting
- ▶  $\rightsquigarrow$  height function

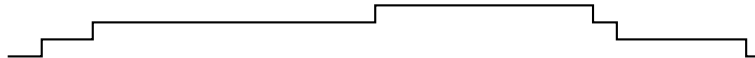

- ▶ Member of the KPZ Universality class ( $\frac{1}{3}$ -power scalings, GO/UE limit distributions) [Krug-Spohn '92]

# Polynuclear Growth (PNG) [Hammersley '72]

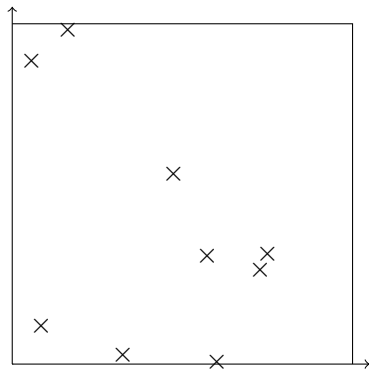

# Polynuclear Growth (PNG) [Hammersley '72]

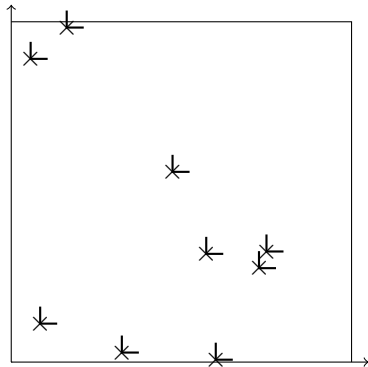











# Polynuclear Growth (PNG) [Hammersley '72]

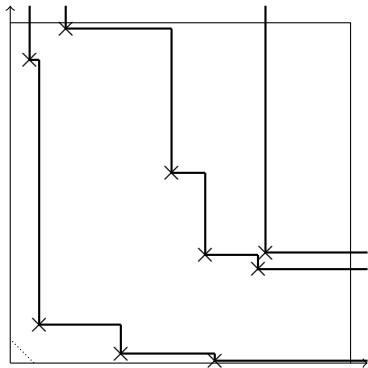





# Polynuclear Growth (PNG) [Hammersley '72]

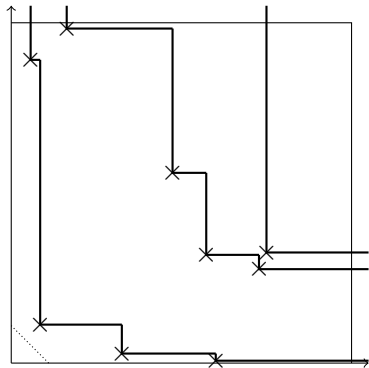

# Polynuclear Growth (PNG) [Hammersley '72]

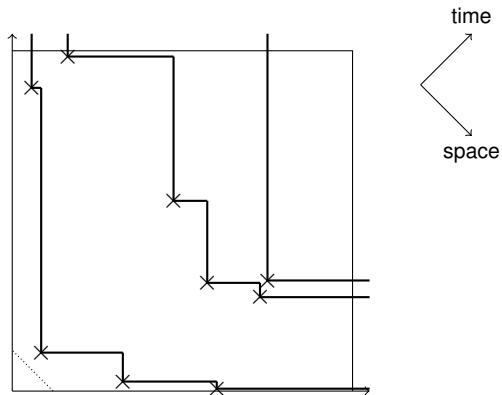

# Polynuclear Growth (PNG) [Hammersley '72]

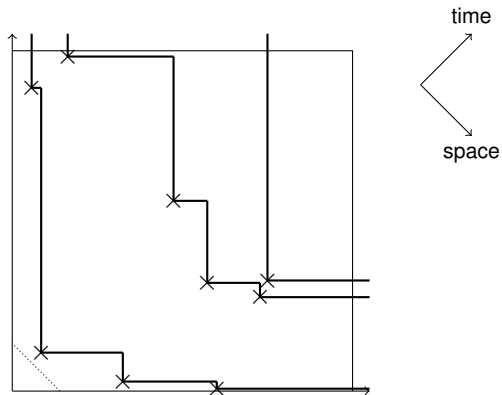

# Polynuclear Growth (PNG) [Hammersley '72]

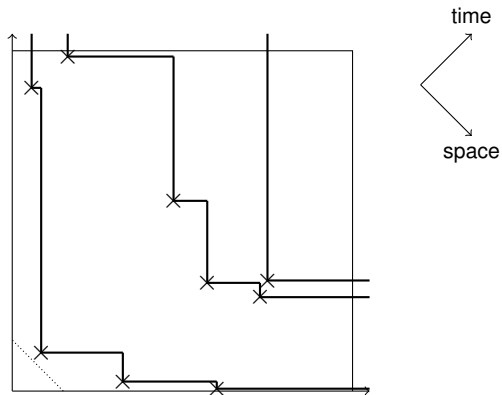

# Polynuclear Growth (PNG) [Hammersley '72]

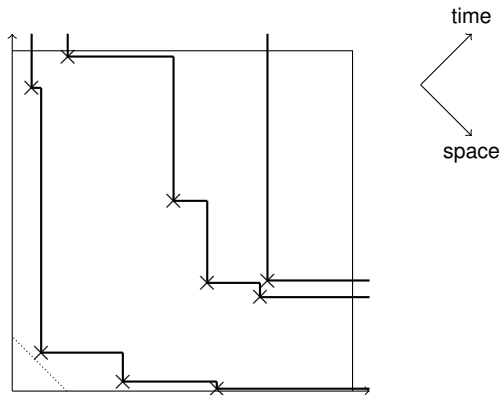

# Polynuclear Growth (PNG) [Hammersley '72]

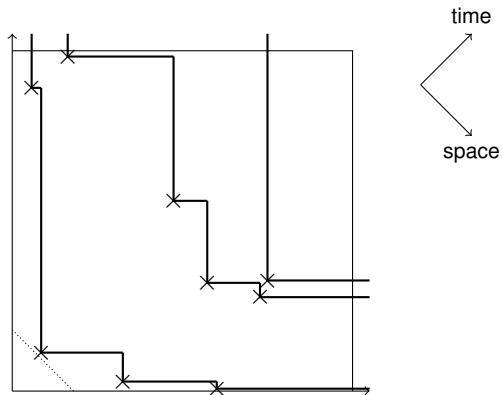

# Polynuclear Growth (PNG) [Hammersley '72]

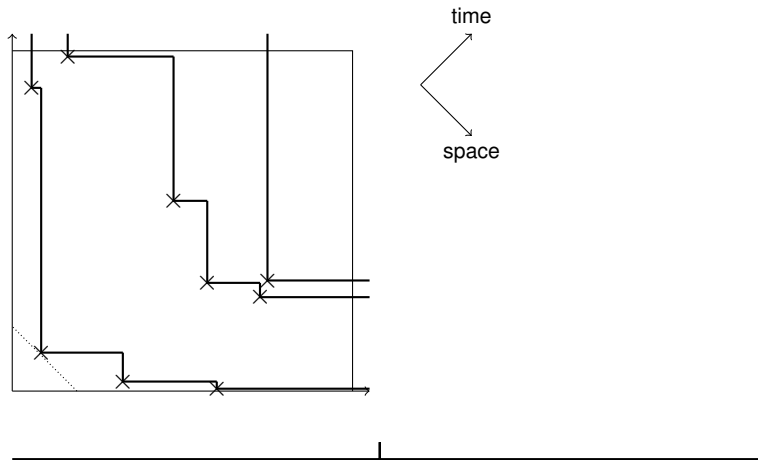

# Polynuclear Growth (PNG) [Hammersley '72]

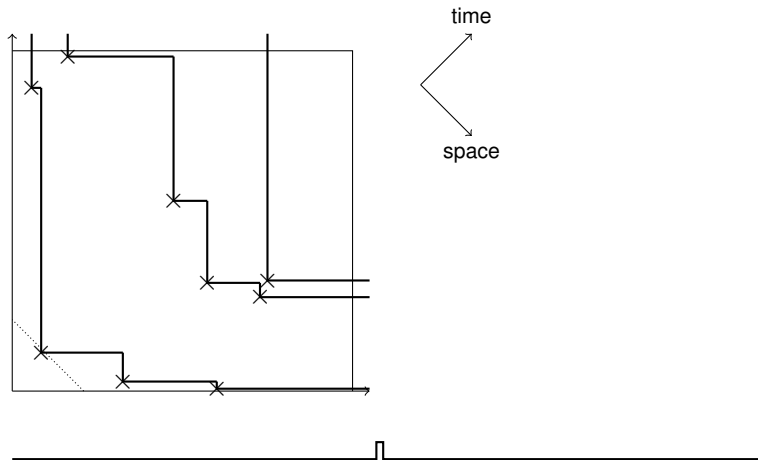

# Polynuclear Growth (PNG) [Hammersley '72]

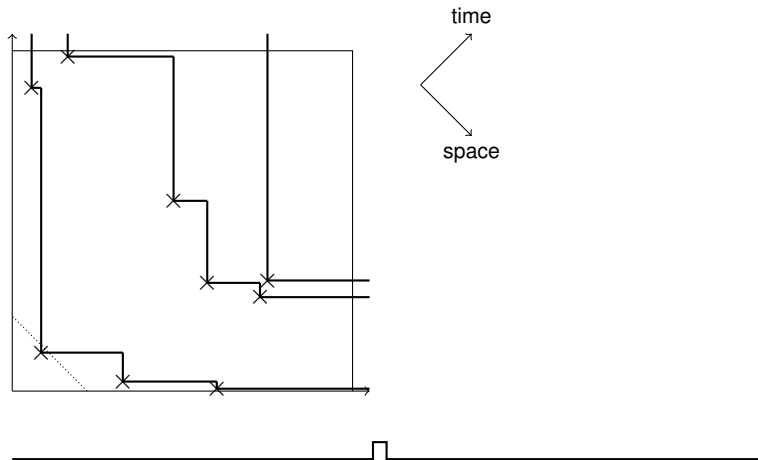

# Polynuclear Growth (PNG) [Hammersley '72]

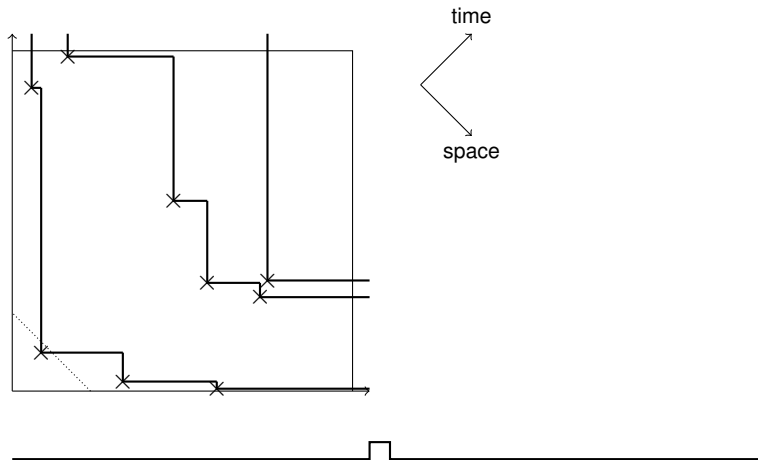

# Polynuclear Growth (PNG) [Hammersley '72]

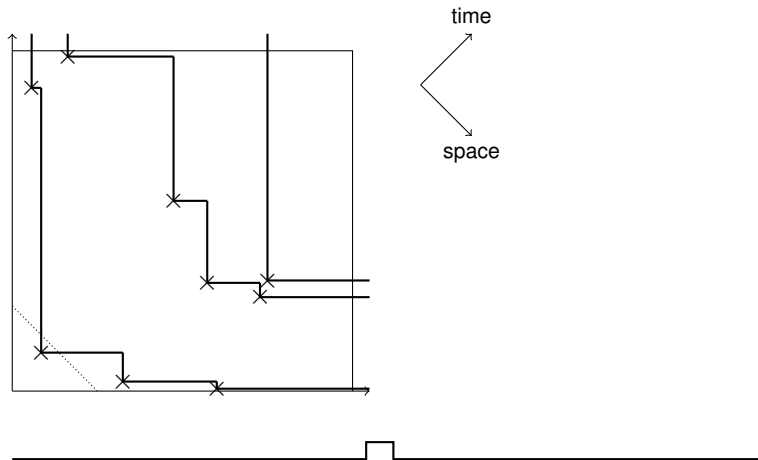

# Polynuclear Growth (PNG) [Hammersley '72]

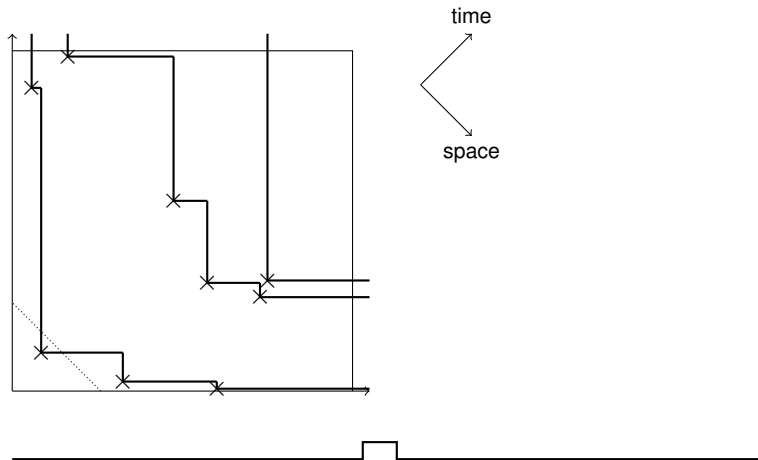

# Polynuclear Growth (PNG) [Hammersley '72]

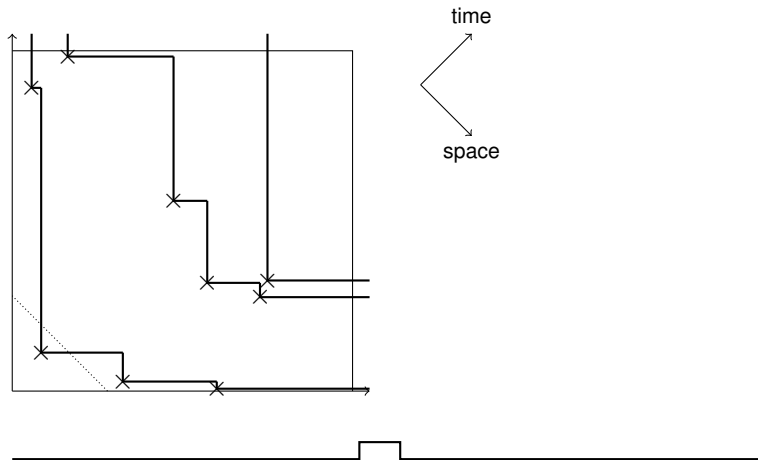

# Polynuclear Growth (PNG) [Hammersley '72]

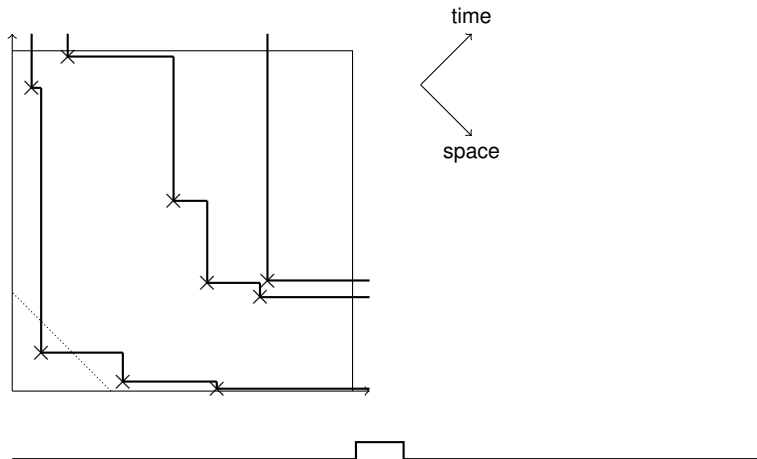

# Polynuclear Growth (PNG) [Hammersley '72]

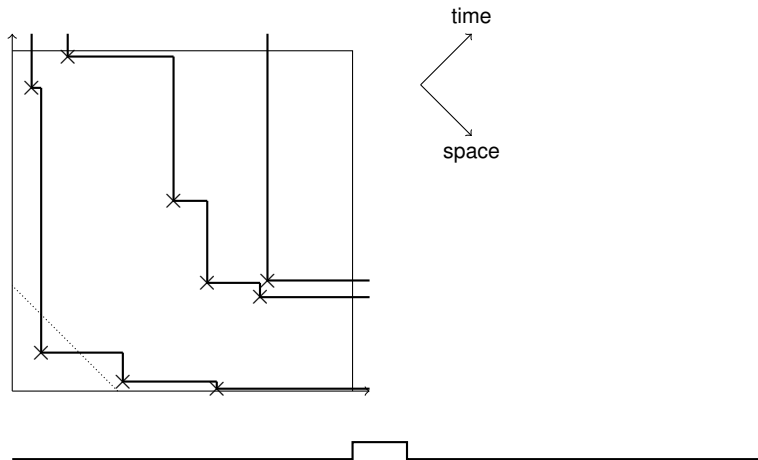

# Polynuclear Growth (PNG) [Hammersley '72]

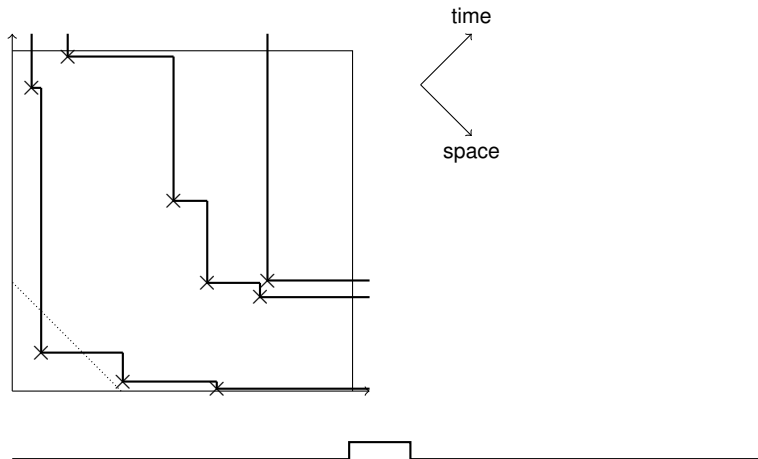

# Polynuclear Growth (PNG) [Hammersley '72]

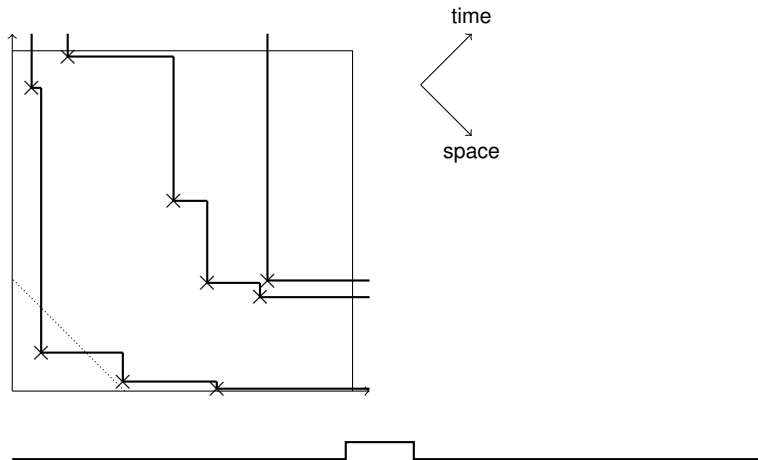

# Polynuclear Growth (PNG) [Hammersley '72]

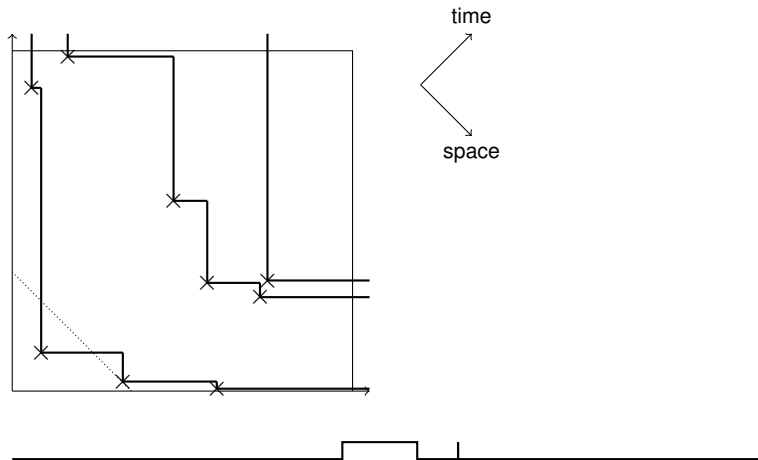

# Polynuclear Growth (PNG) [Hammersley '72]

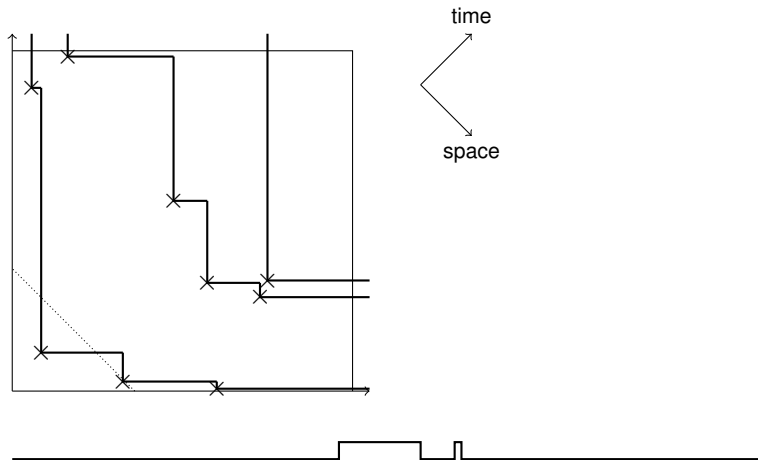

# Polynuclear Growth (PNG) [Hammersley '72]

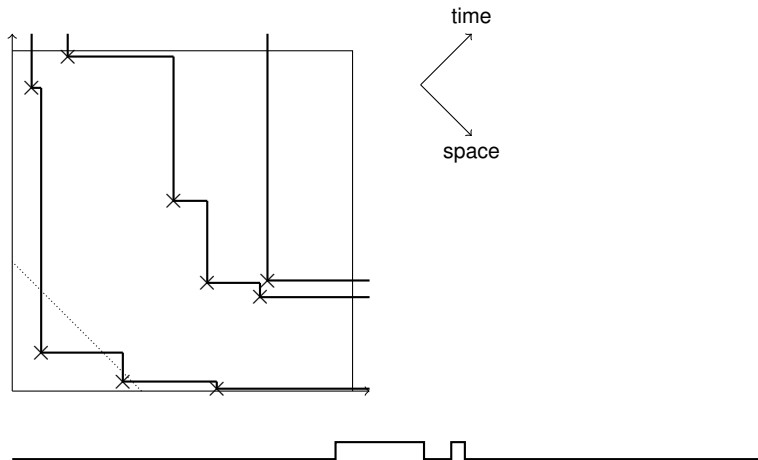

# Polynuclear Growth (PNG) [Hammersley '72]

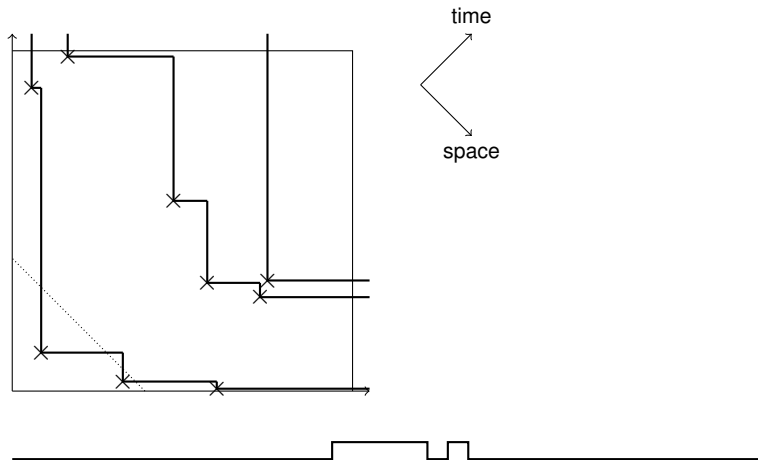

# Polynuclear Growth (PNG) [Hammersley '72]

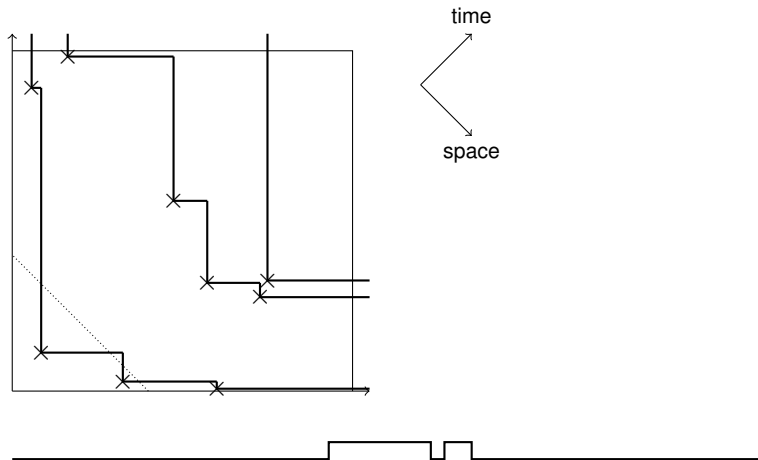

# Polynuclear Growth (PNG) [Hammersley '72]

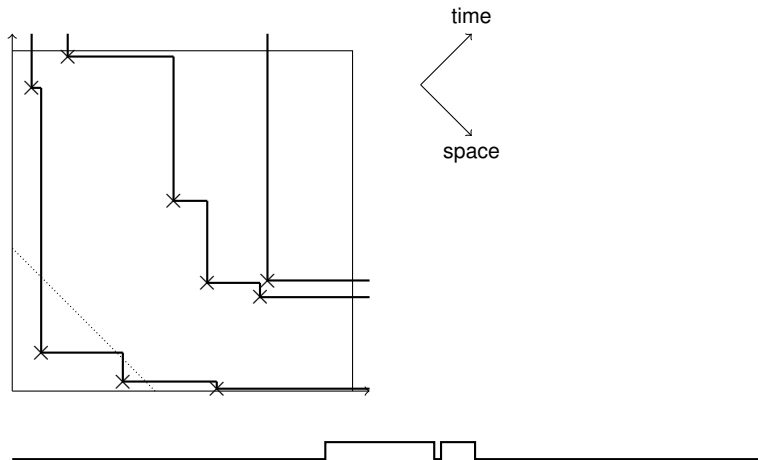

# Polynuclear Growth (PNG) [Hammersley '72]

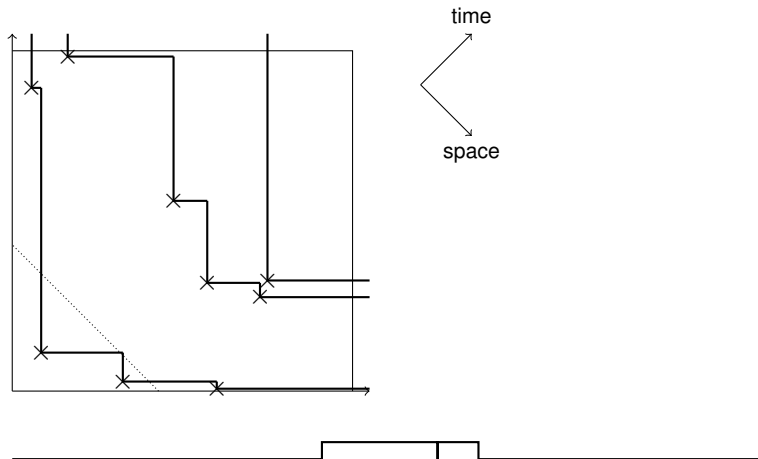

# Polynuclear Growth (PNG) [Hammersley '72]

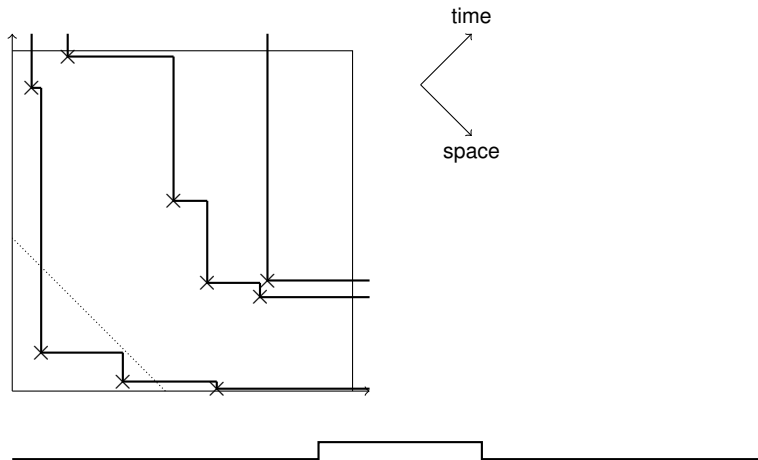

# Polynuclear Growth (PNG) [Hammersley '72]

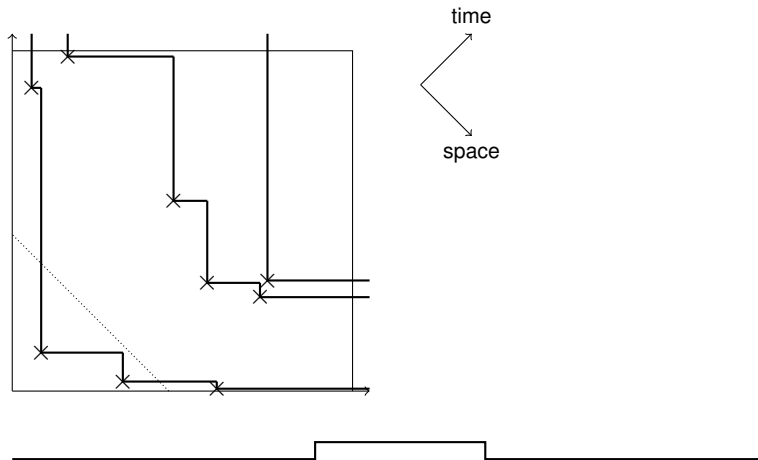

# Polynuclear Growth (PNG) [Hammersley '72]

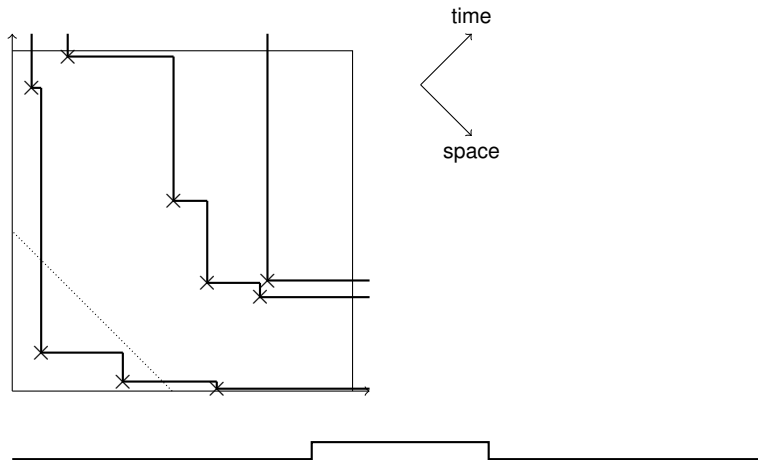

# Polynuclear Growth (PNG) [Hammersley '72]

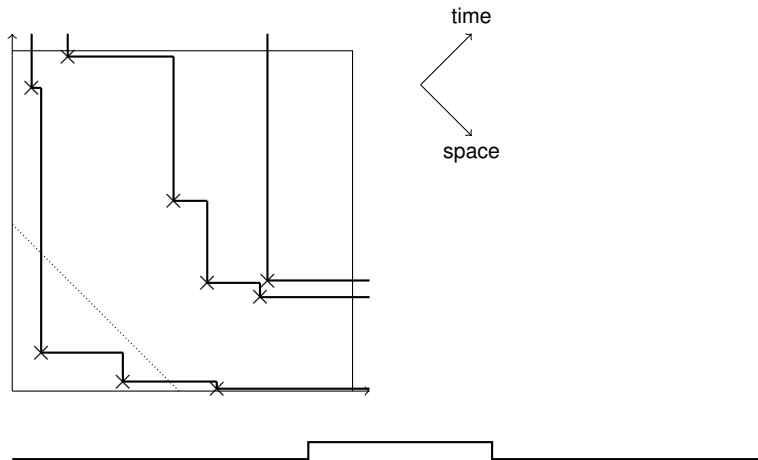

# Polynuclear Growth (PNG) [Hammersley '72]

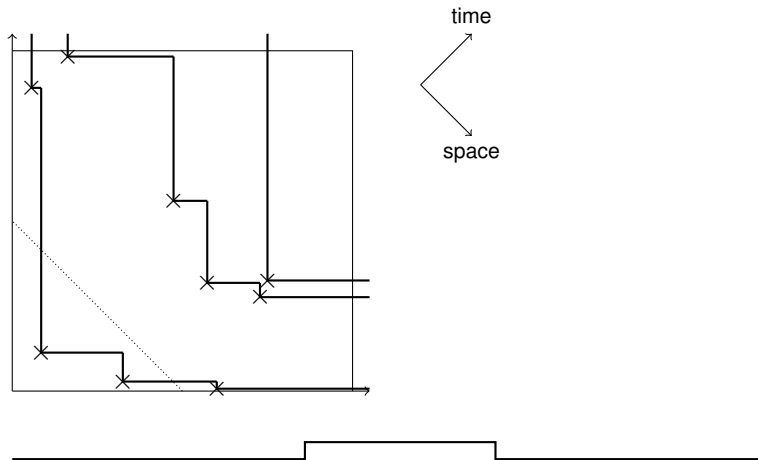

# Polynuclear Growth (PNG) [Hammersley '72]

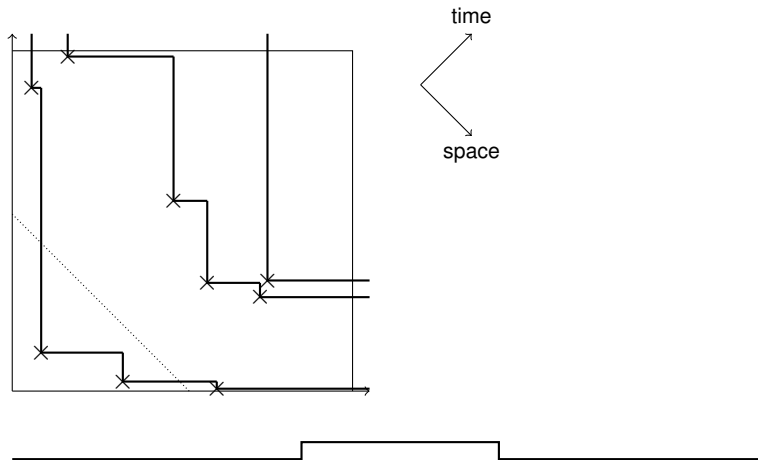

# Polynuclear Growth (PNG) [Hammersley '72]

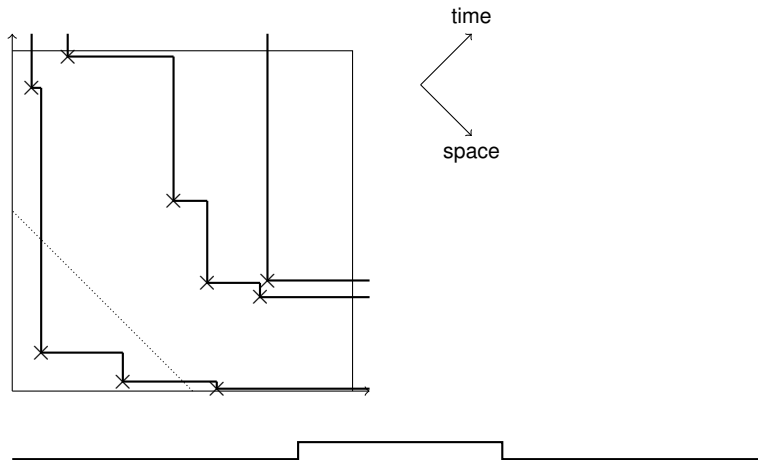

# Polynuclear Growth (PNG) [Hammersley '72]

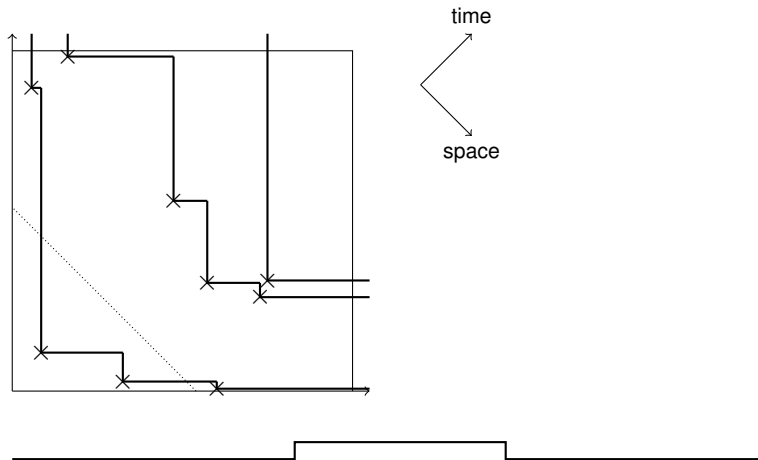

# Polynuclear Growth (PNG) [Hammersley '72]

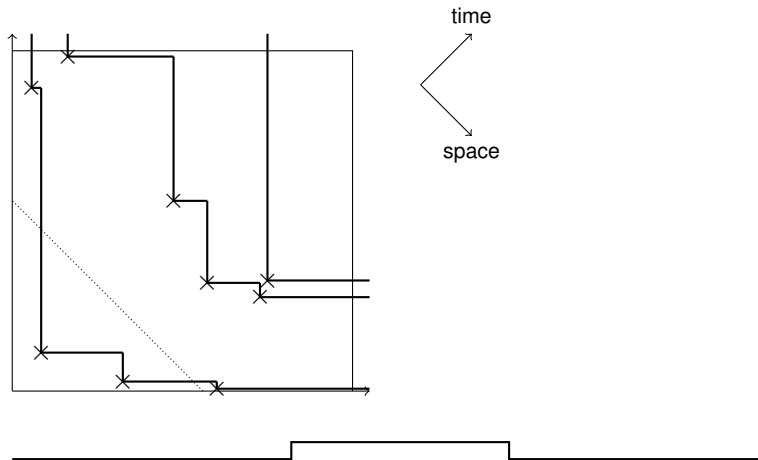

# Polynuclear Growth (PNG) [Hammersley '72]

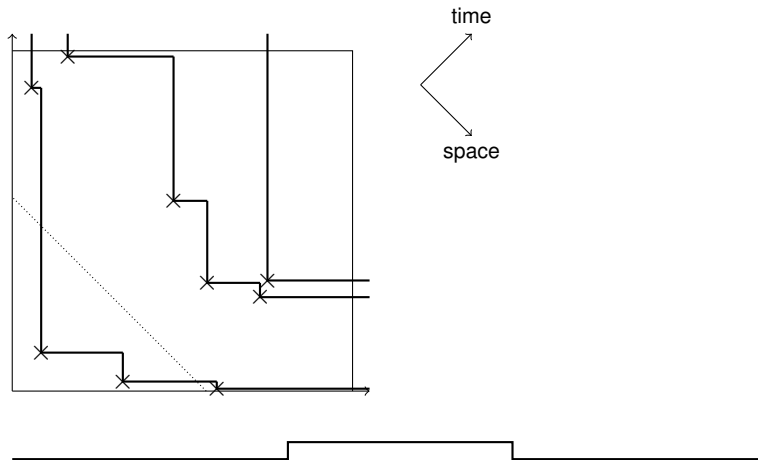

# Polynuclear Growth (PNG) [Hammersley '72]

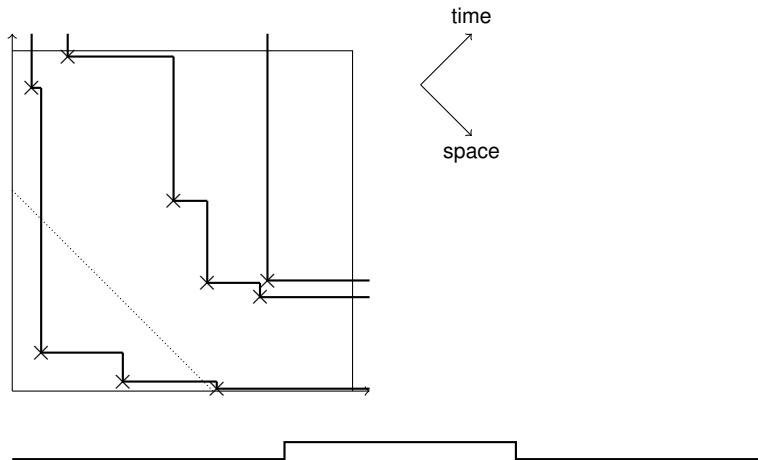

# Polynuclear Growth (PNG) [Hammersley '72]

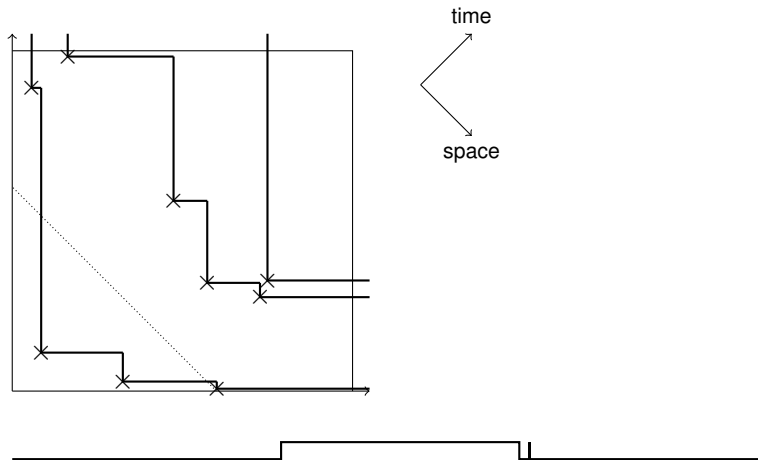

# Polynuclear Growth (PNG) [Hammersley '72]

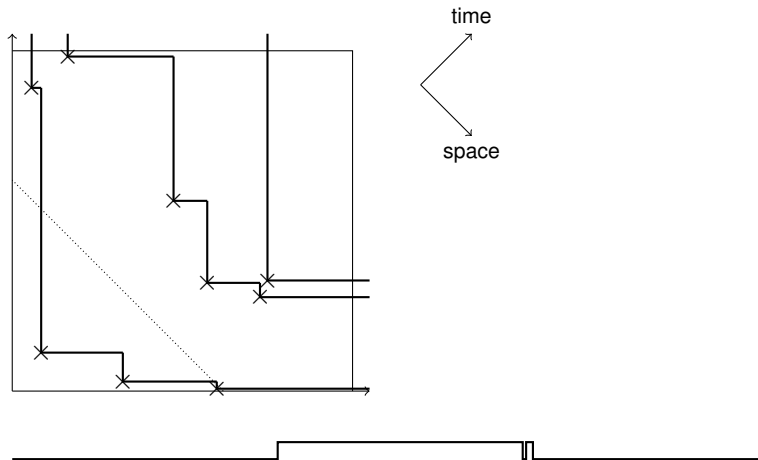

# Polynuclear Growth (PNG) [Hammersley '72]

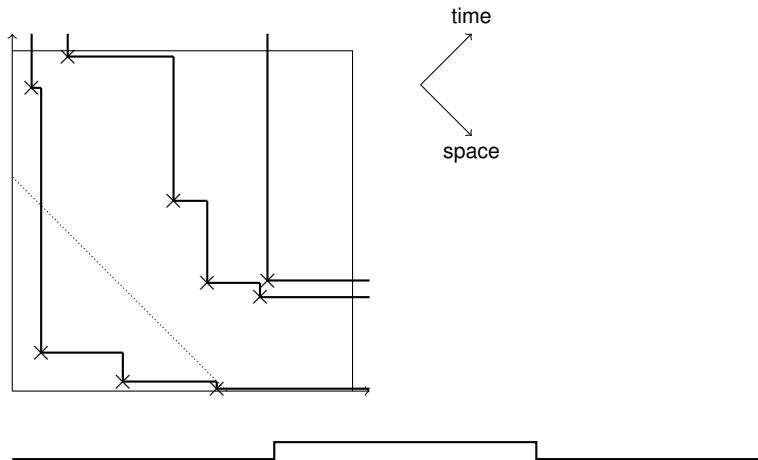

# Polynuclear Growth (PNG) [Hammersley '72]

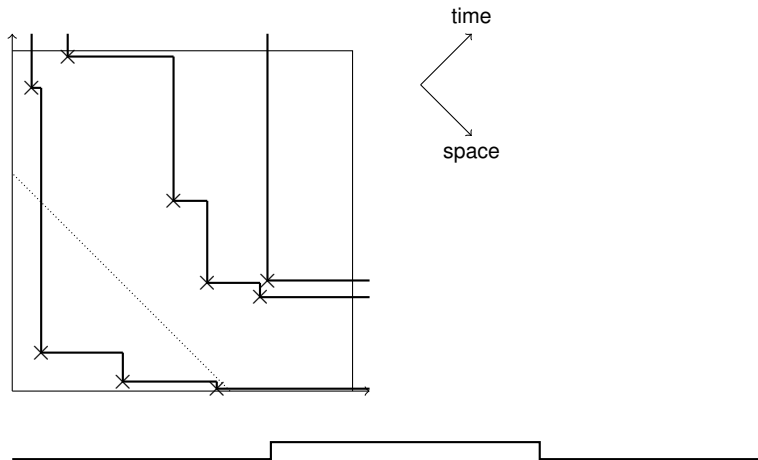

# Polynuclear Growth (PNG) [Hammersley '72]

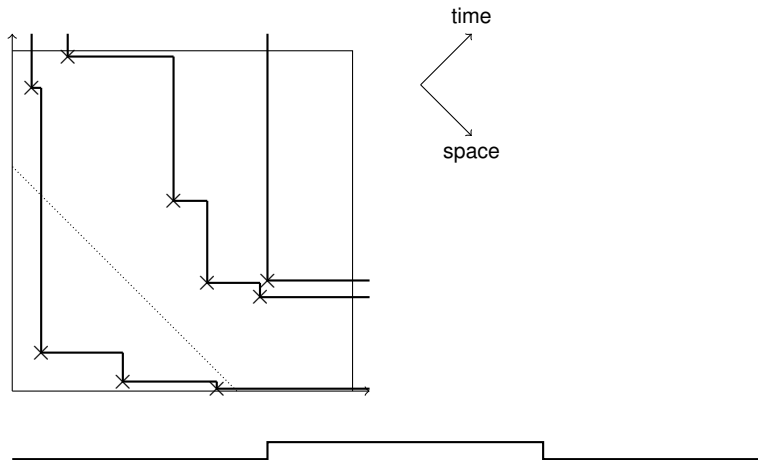

# Polynuclear Growth (PNG) [Hammersley '72]

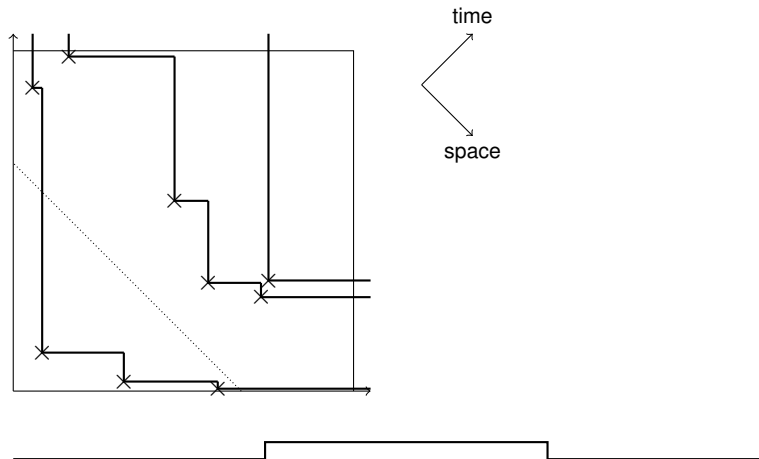

# Polynuclear Growth (PNG) [Hammersley '72]

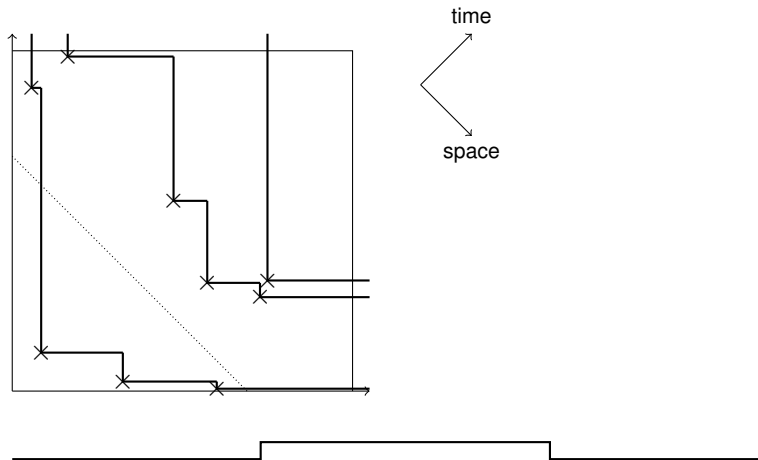

# Polynuclear Growth (PNG) [Hammersley '72]

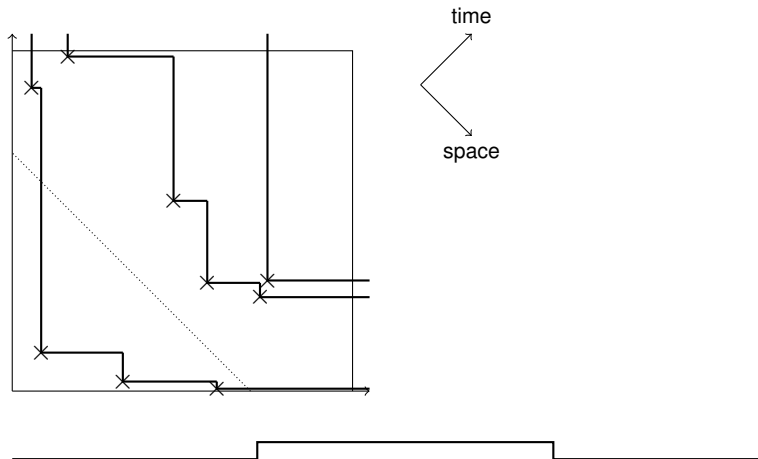

# Polynuclear Growth (PNG) [Hammersley '72]

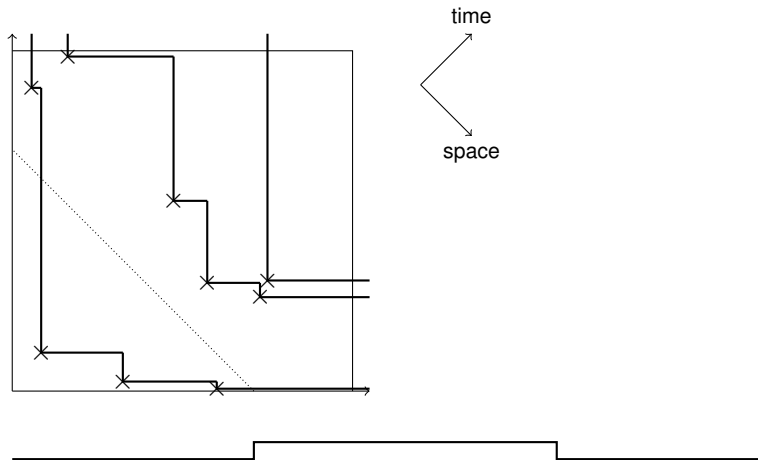

# Polynuclear Growth (PNG) [Hammersley '72]

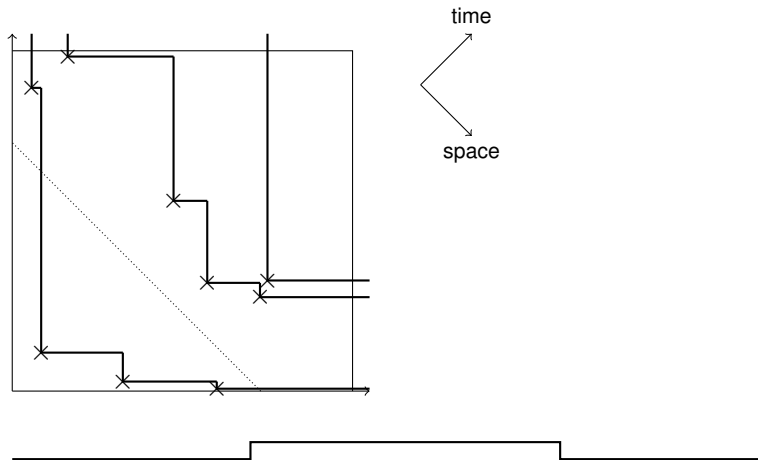

# Polynuclear Growth (PNG) [Hammersley '72]

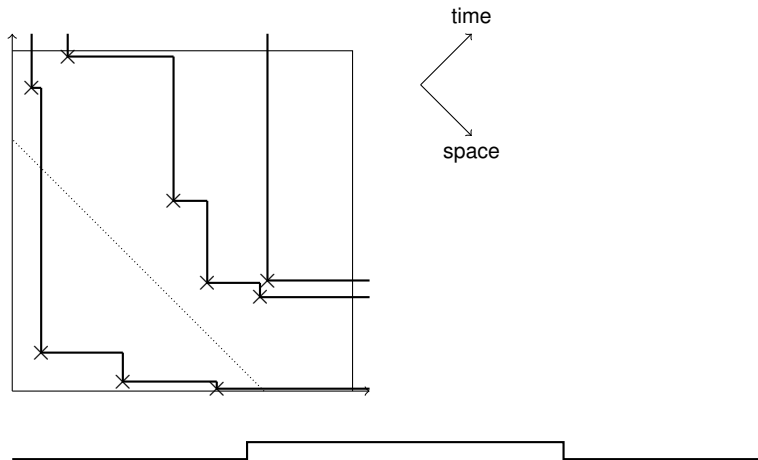



# Polynuclear Growth (PNG) [Hammersley '72]

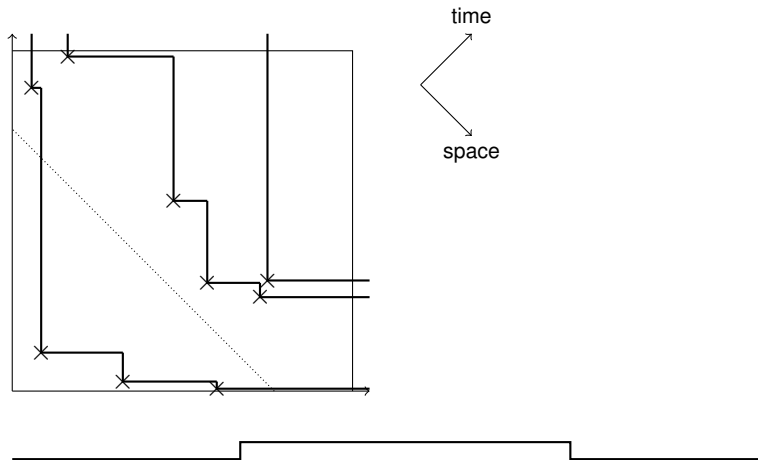

# Polynuclear Growth (PNG) [Hammersley '72]

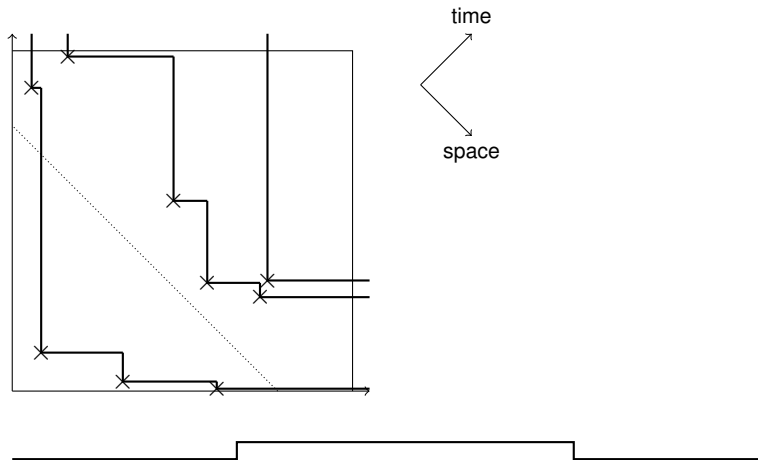

# Polynuclear Growth (PNG) [Hammersley '72]

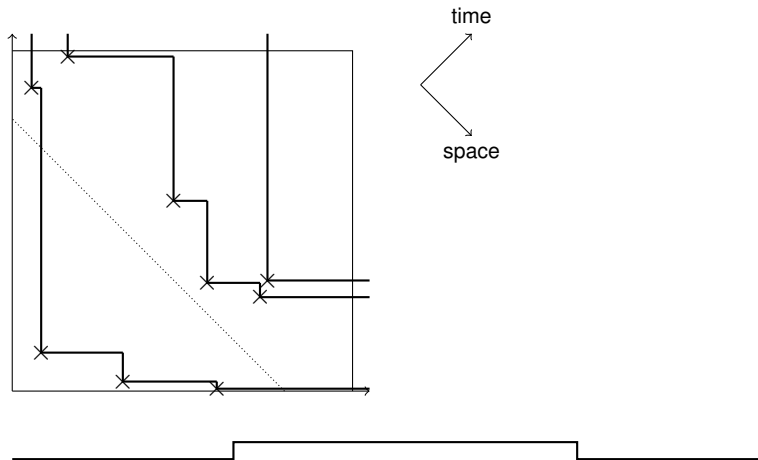

# Polynuclear Growth (PNG) [Hammersley '72]

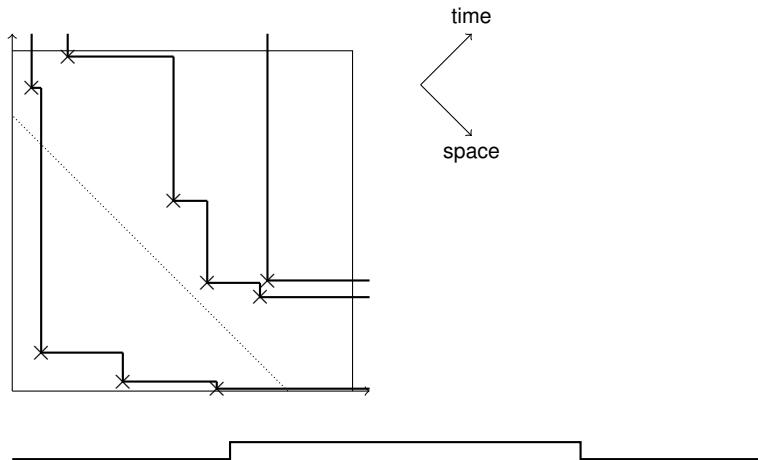

# Polynuclear Growth (PNG) [Hammersley '72]

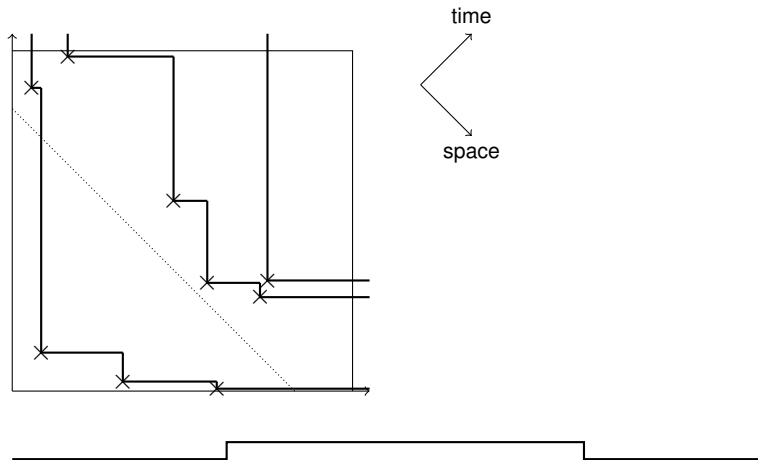

# Polynuclear Growth (PNG) [Hammersley '72]

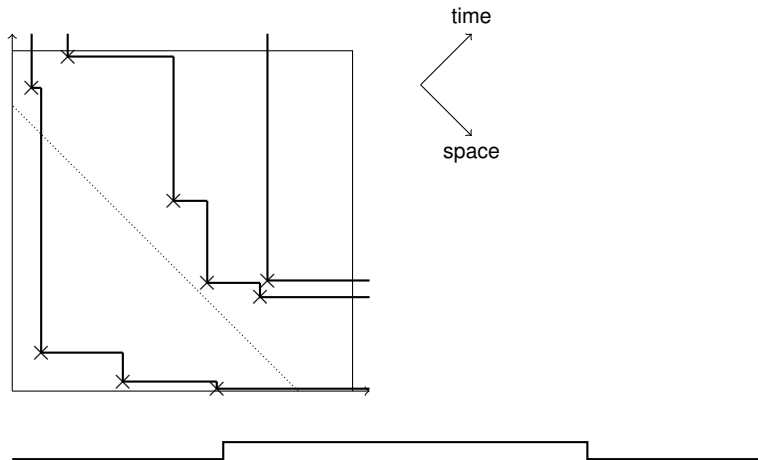

# Polynuclear Growth (PNG) [Hammersley '72]

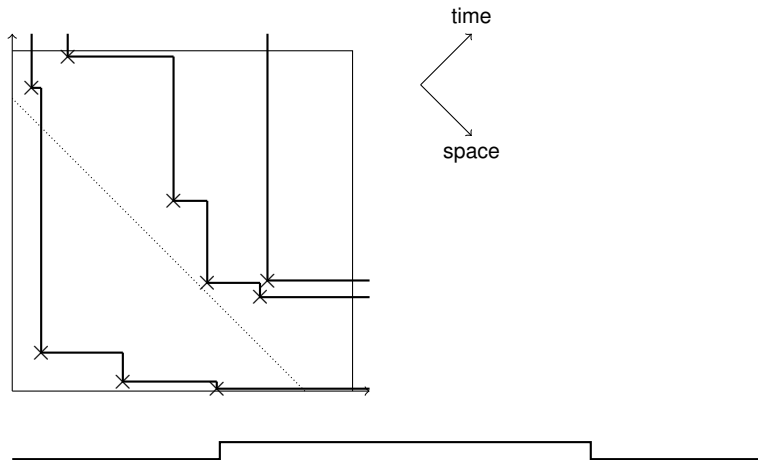

# Polynuclear Growth (PNG) [Hammersley '72]

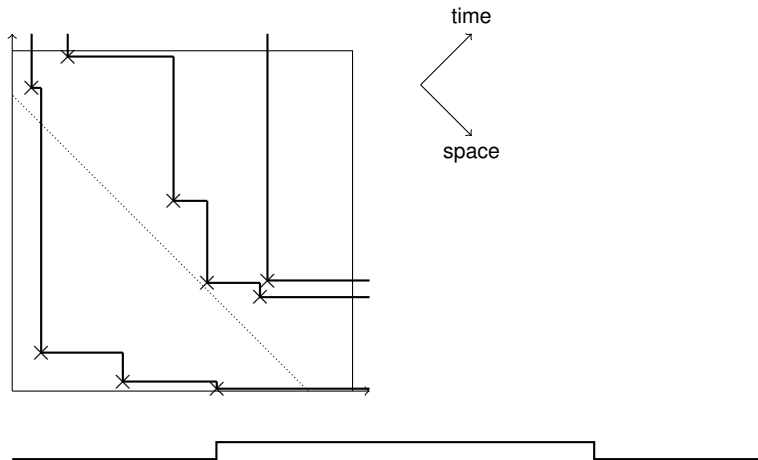

# Polynuclear Growth (PNG) [Hammersley '72]

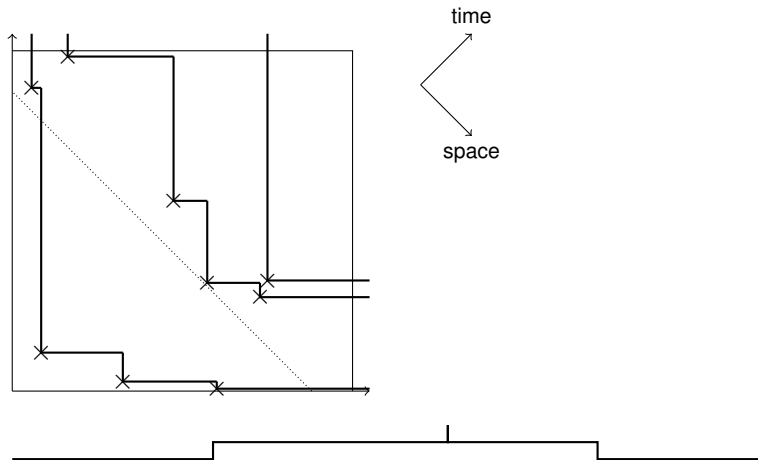

# Polynuclear Growth (PNG) [Hammersley '72]

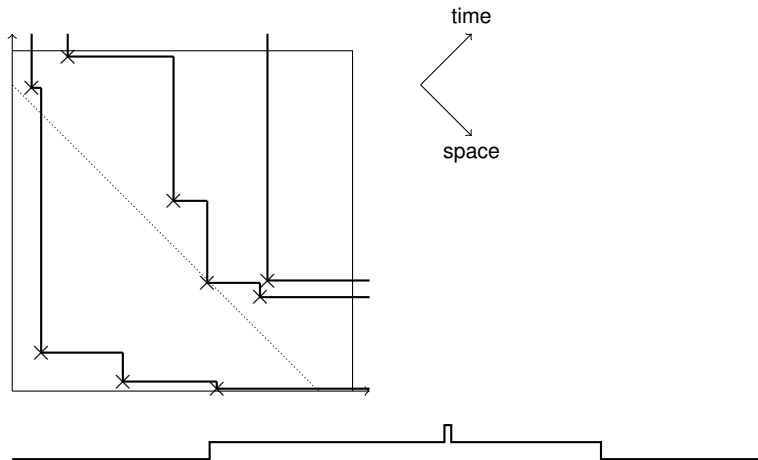

# Polynuclear Growth (PNG) [Hammersley '72]

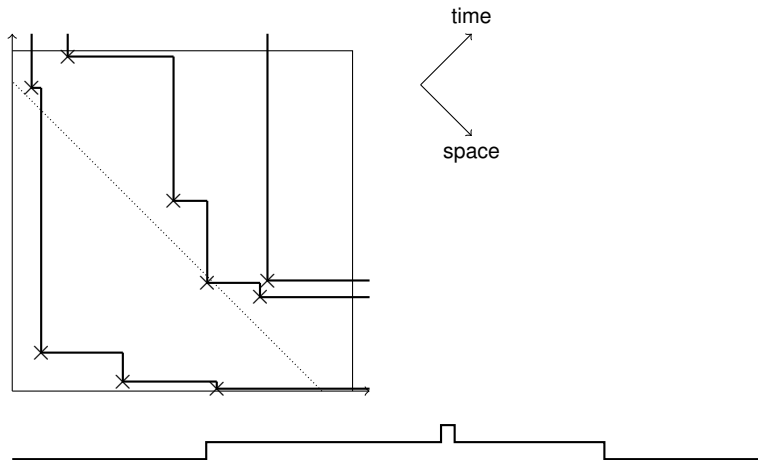

# Polynuclear Growth (PNG) [Hammersley '72]

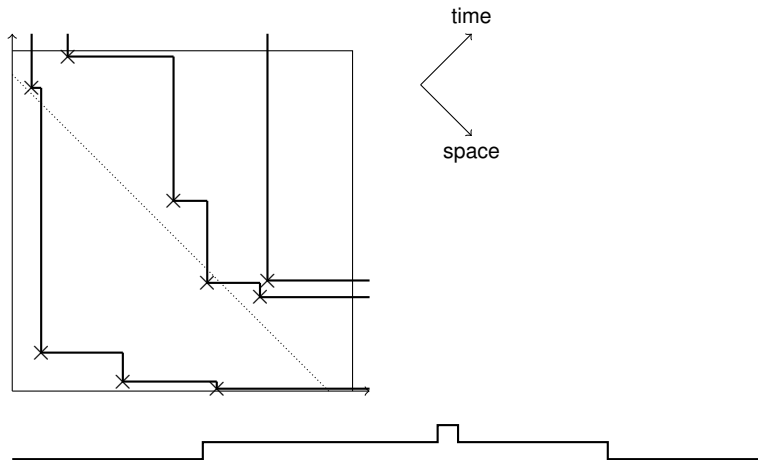

# Polynuclear Growth (PNG) [Hammersley '72]

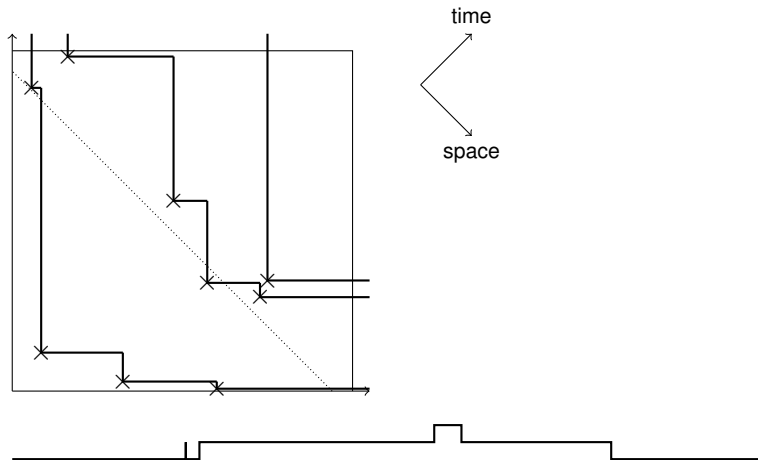

# Polynuclear Growth (PNG) [Hammersley '72]

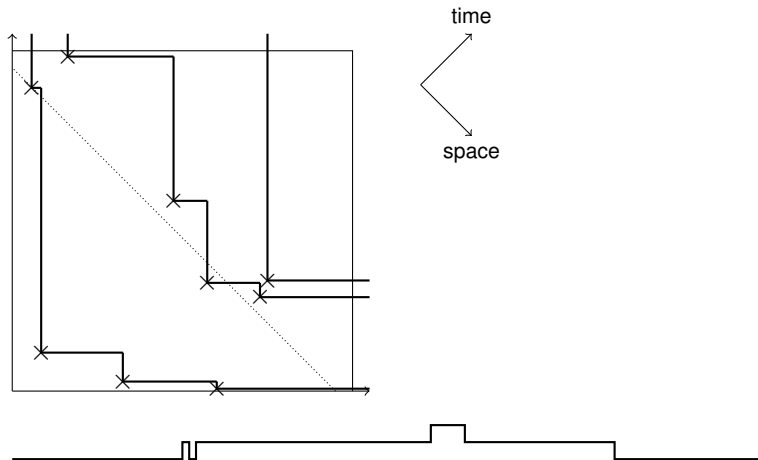

# Polynuclear Growth (PNG) [Hammersley '72]

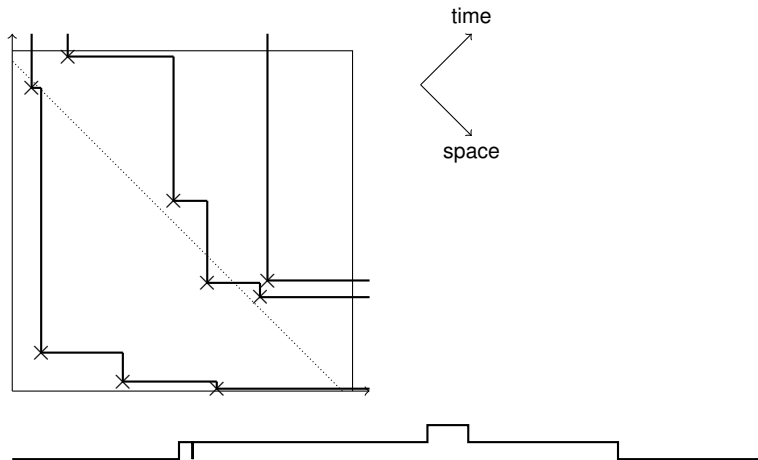

# Polynuclear Growth (PNG) [Hammersley '72]

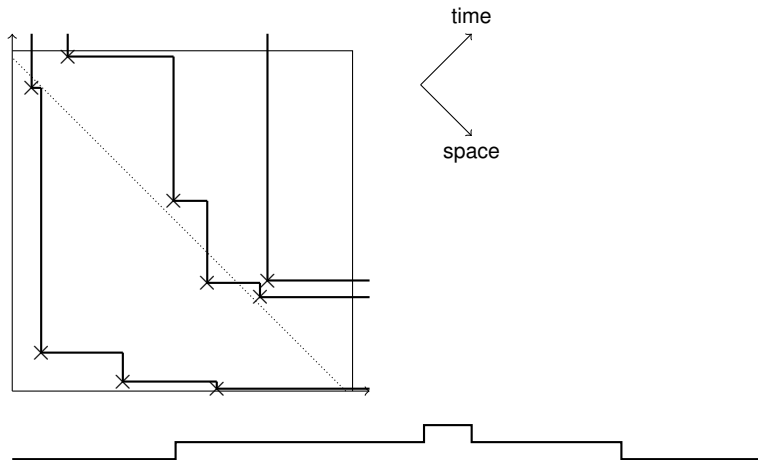

# Polynuclear Growth (PNG) [Hammersley '72]

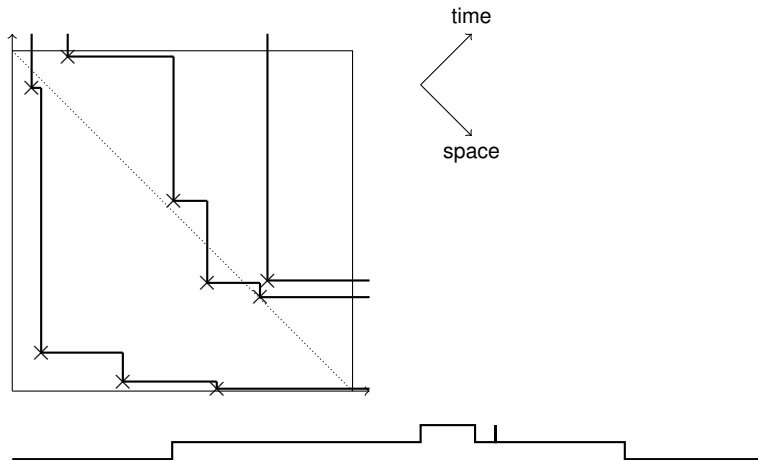

# Polynuclear Growth (PNG) [Hammersley '72]

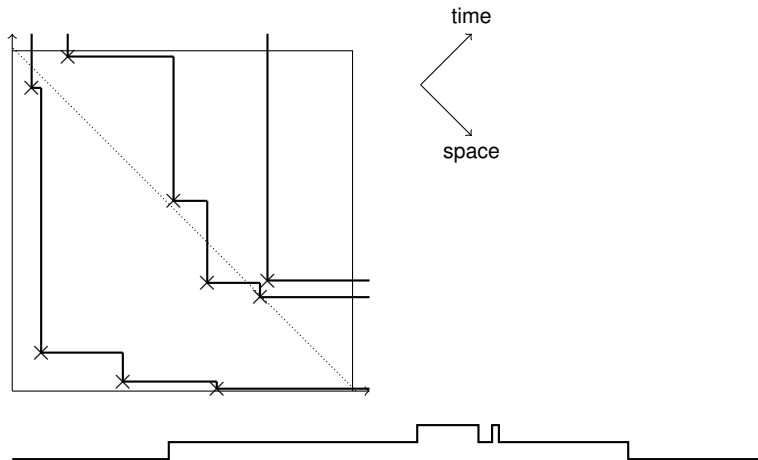

# Polynuclear Growth (PNG) [Hammersley '72]

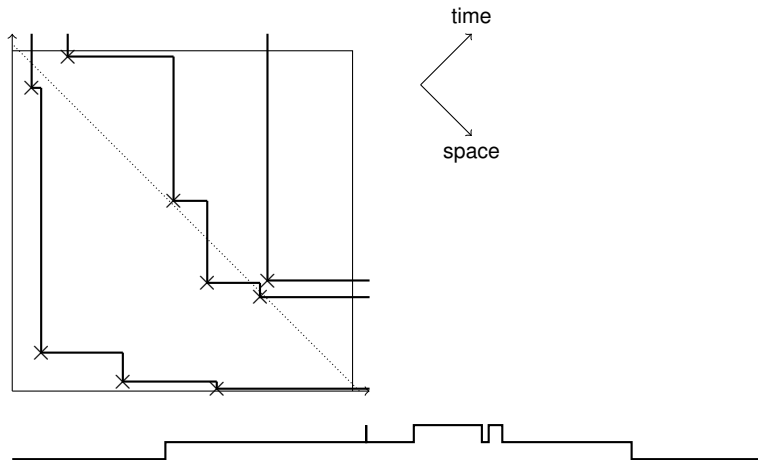

# Polynuclear Growth (PNG) [Hammersley '72]

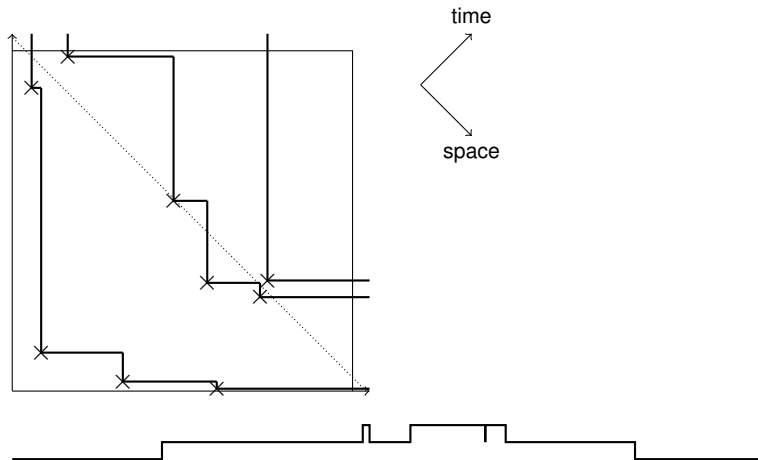

# Polynuclear Growth (PNG) [Hammersley '72]

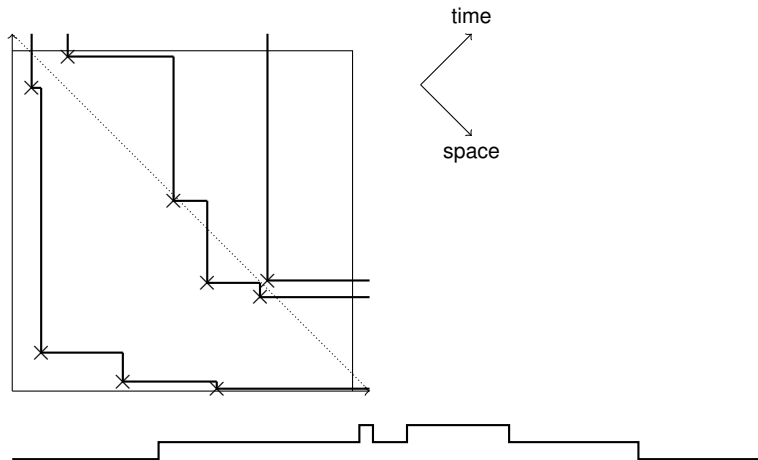

# Polynuclear Growth (PNG) [Hammersley '72]

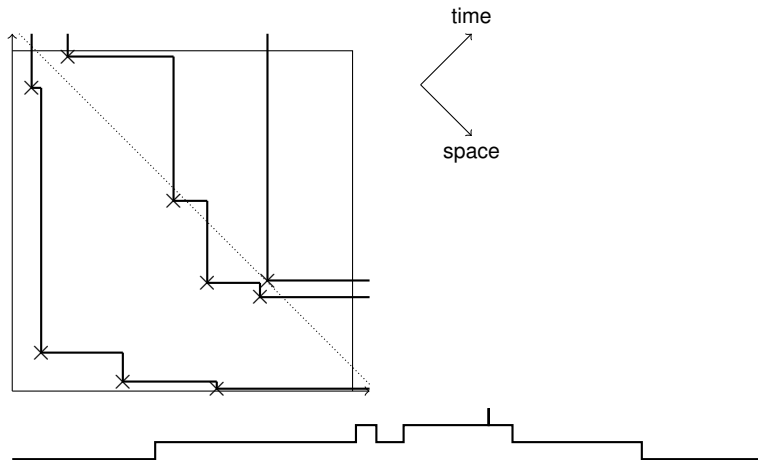

# Polynuclear Growth (PNG) [Hammersley '72]

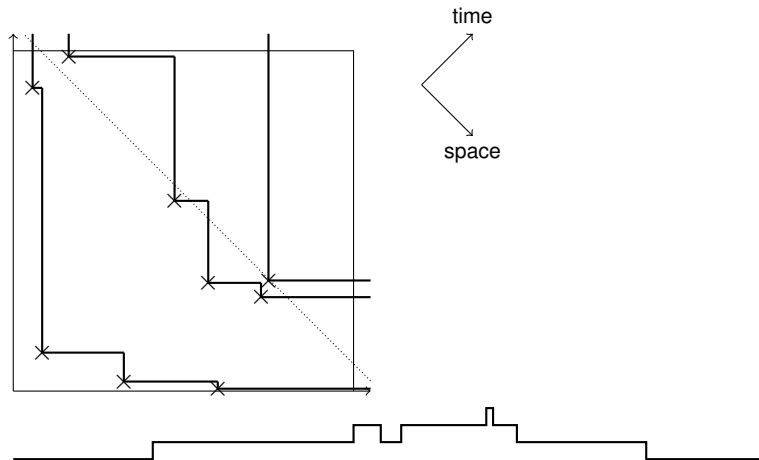

# Polynuclear Growth (PNG) [Hammersley '72]

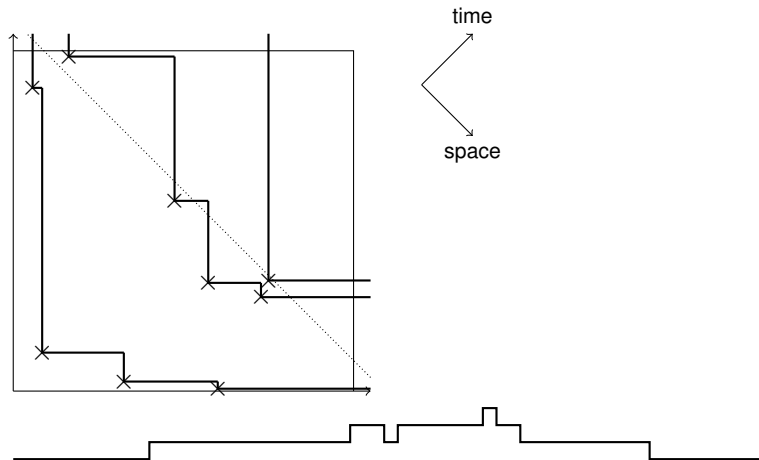

# Polynuclear Growth (PNG) [Hammersley '72]

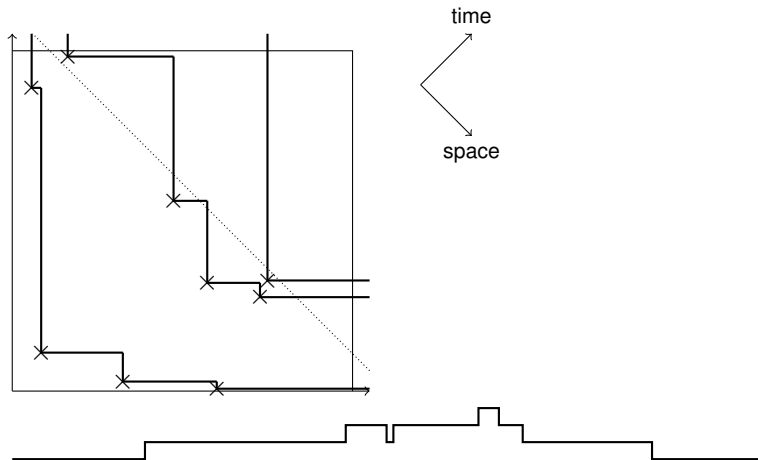

# Polynuclear Growth (PNG) [Hammersley '72]

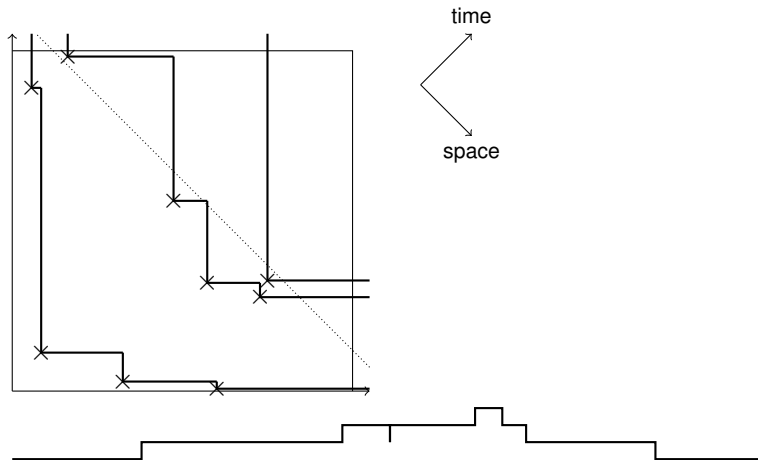

# Polynuclear Growth (PNG) [Hammersley '72]

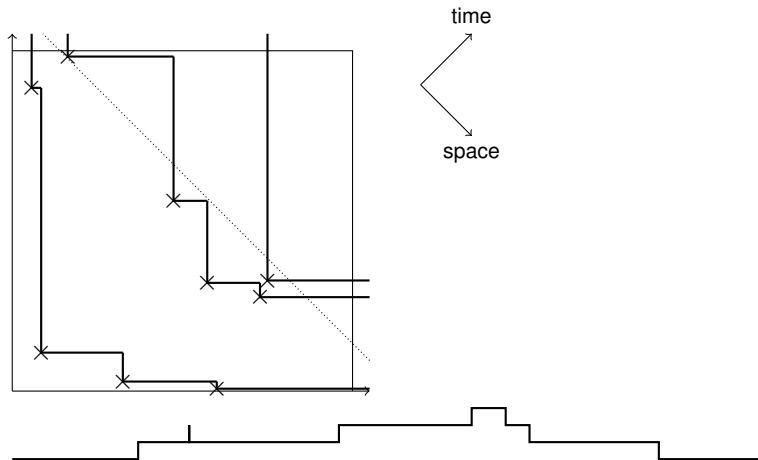

# Polynuclear Growth (PNG) [Hammersley '72]

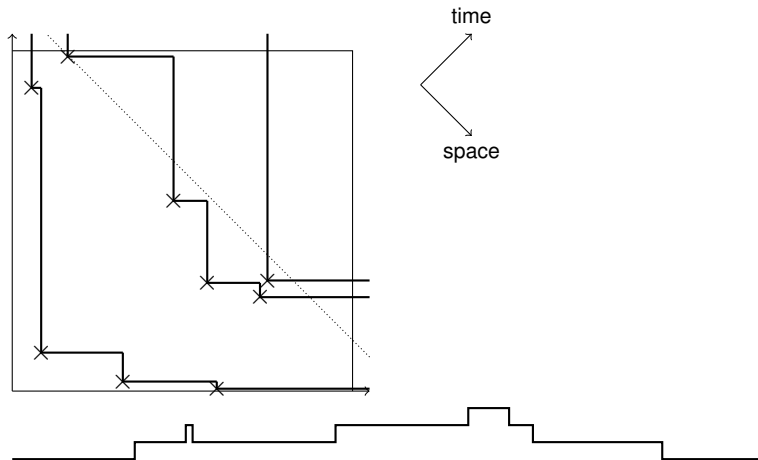

# Polynuclear Growth (PNG) [Hammersley '72]

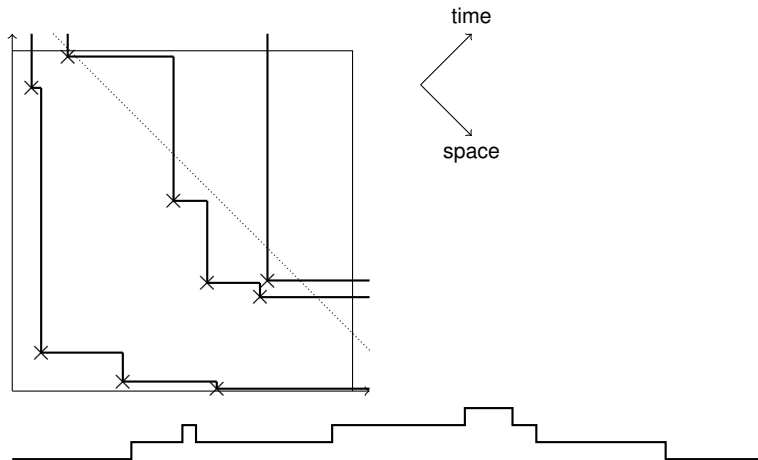

# Polynuclear Growth (PNG) [Hammersley '72]

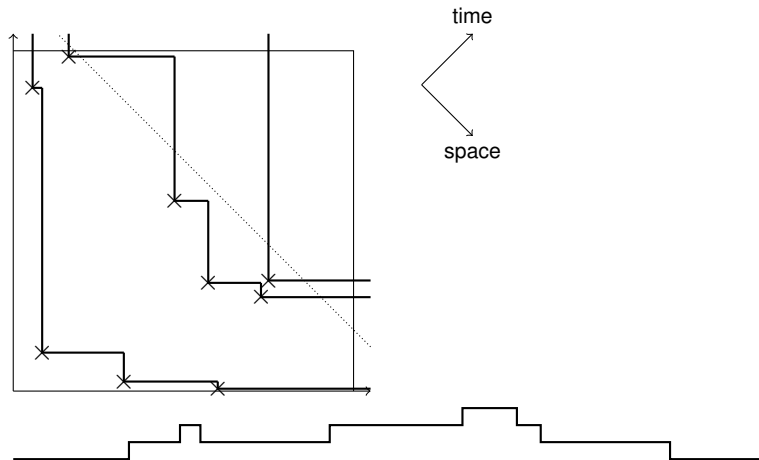

# Polynuclear Growth (PNG) [Hammersley '72]

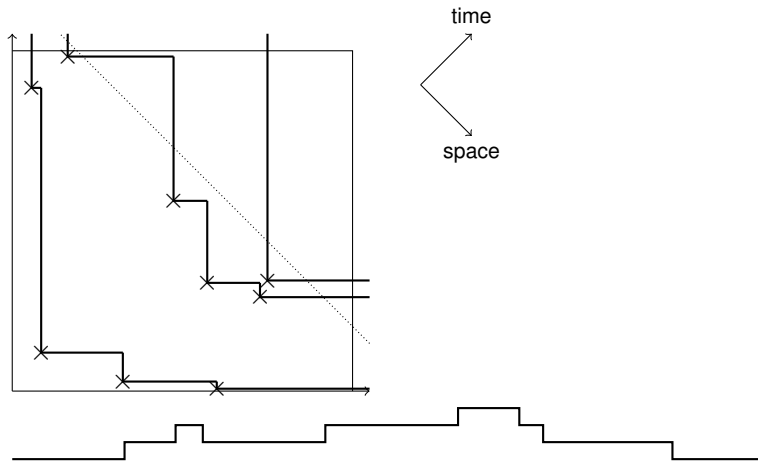

# Polynuclear Growth (PNG) [Hammersley '72]

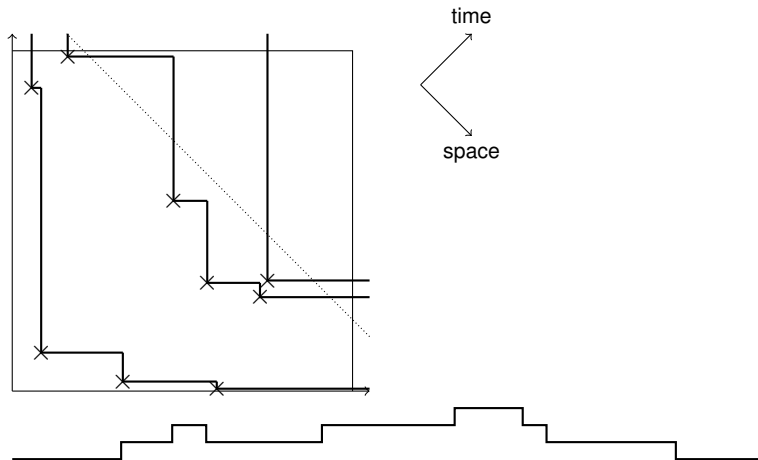

# Polynuclear Growth (PNG) [Hammersley '72]

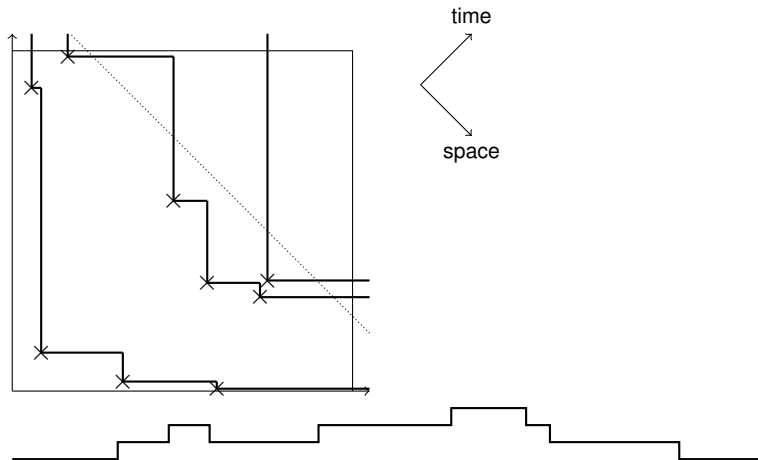

# Polynuclear Growth (PNG) [Hammersley '72]

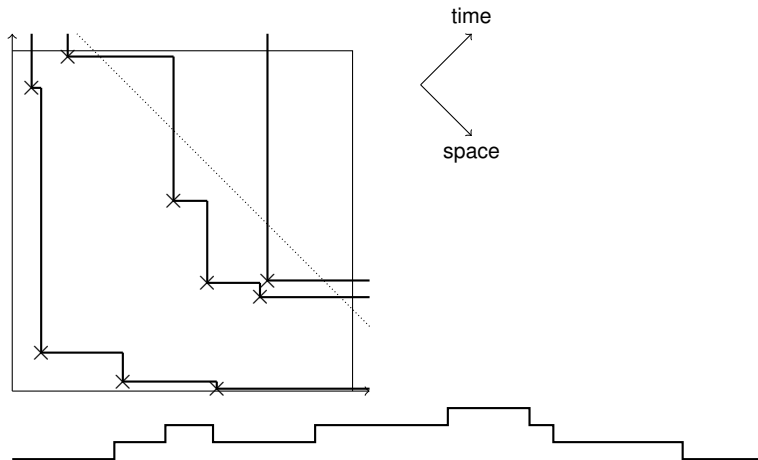

# Polynuclear Growth (PNG) [Hammersley '72]

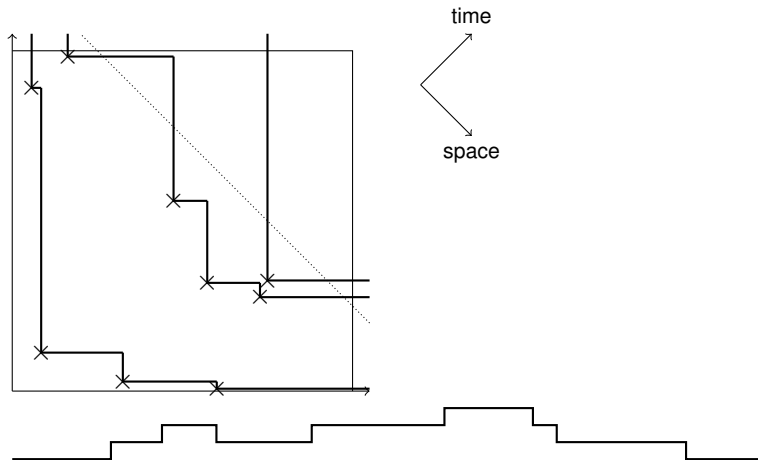

# Polynuclear Growth (PNG) [Hammersley '72]

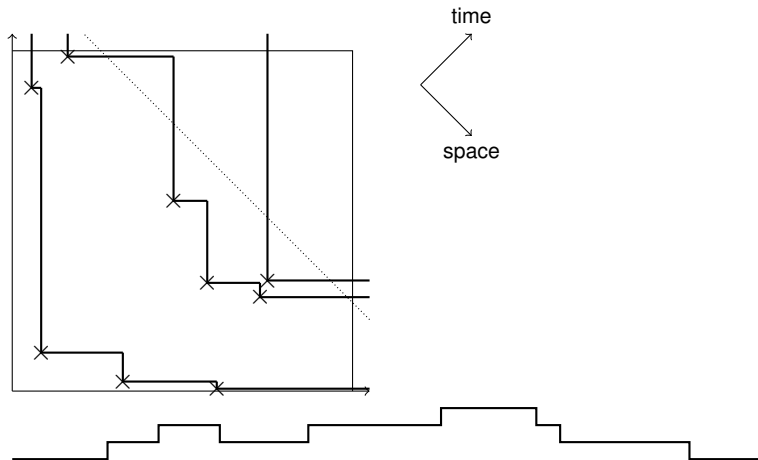

# Polynuclear Growth (PNG) [Hammersley '72]

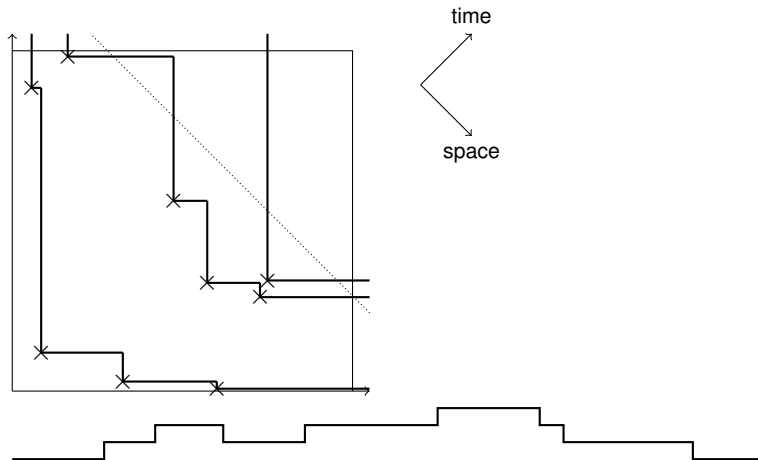

# Polynuclear Growth (PNG) [Hammersley '72]

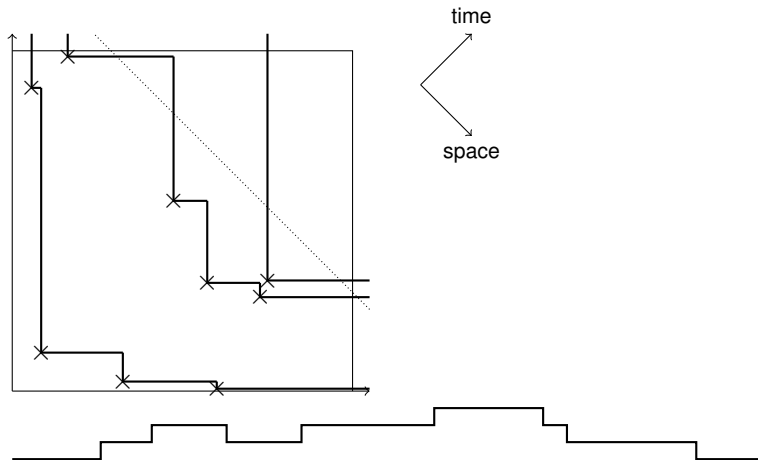

# Polynuclear Growth (PNG) [Hammersley '72]

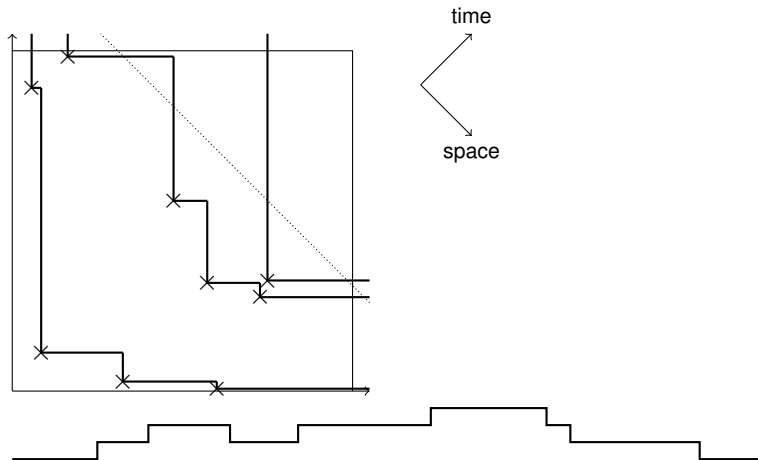

# Polynuclear Growth (PNG) [Hammersley '72]

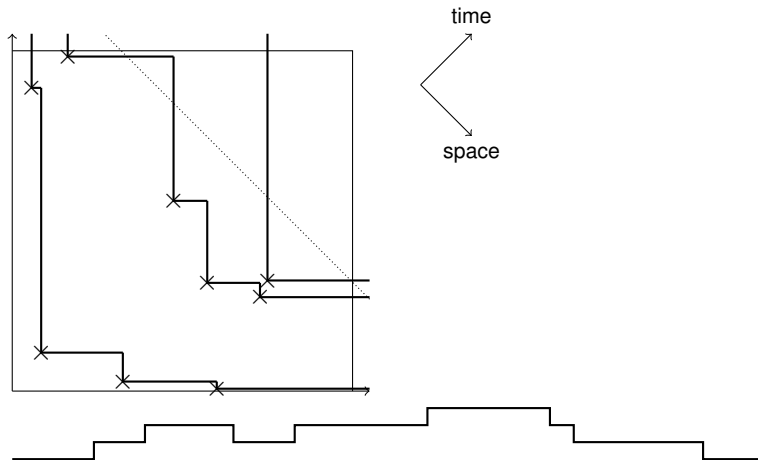

# Polynuclear Growth (PNG) [Hammersley '72]

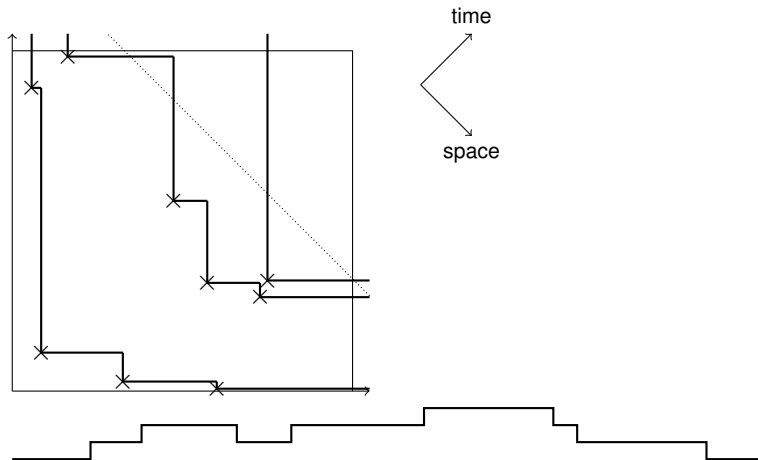

# Polynuclear Growth (PNG) [Hammersley '72]

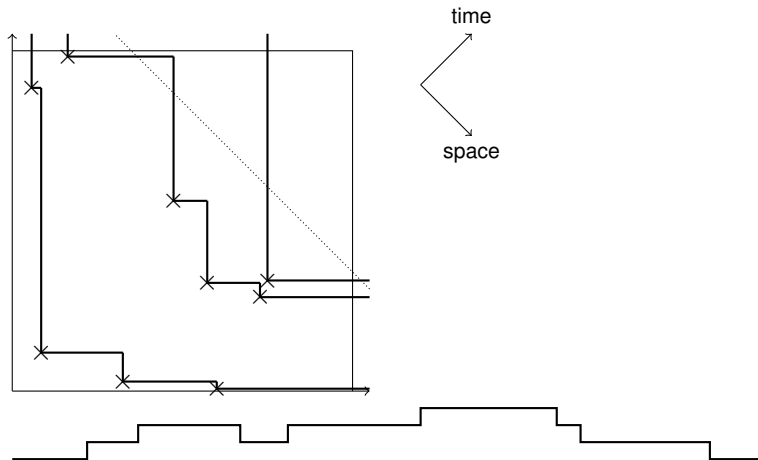

# Polynuclear Growth (PNG) [Hammersley '72]

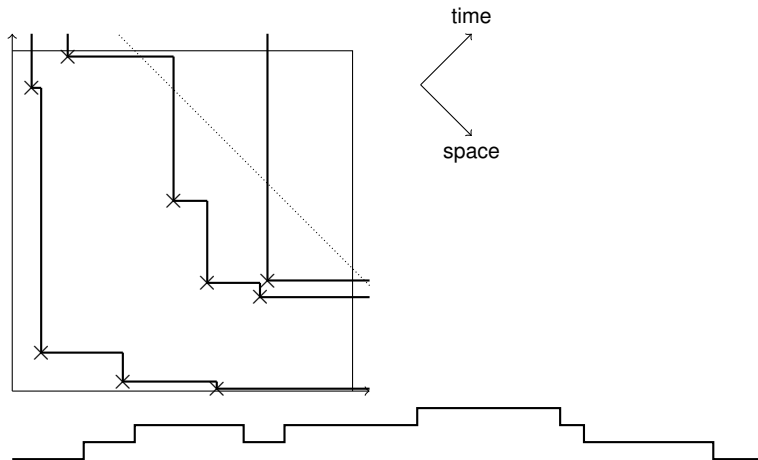

# Polynuclear Growth (PNG) [Hammersley '72]

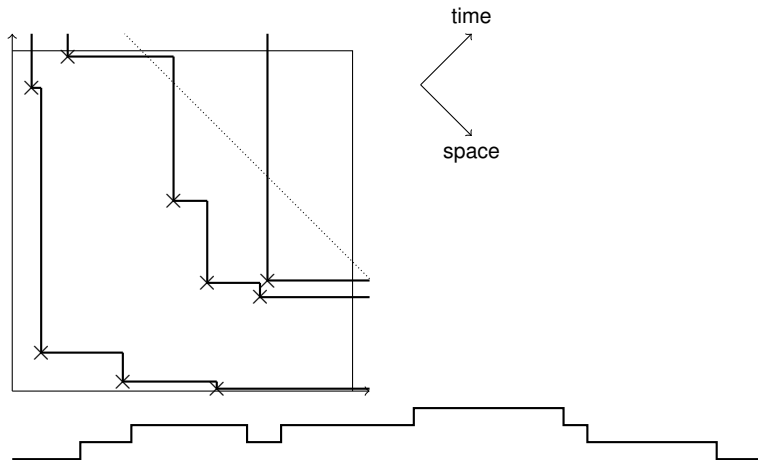

# Polynuclear Growth (PNG) [Hammersley '72]

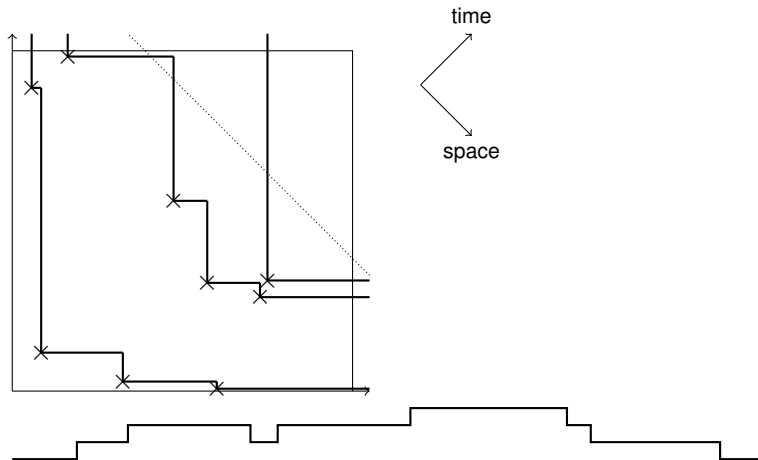

# Polynuclear Growth (PNG) [Hammersley '72]

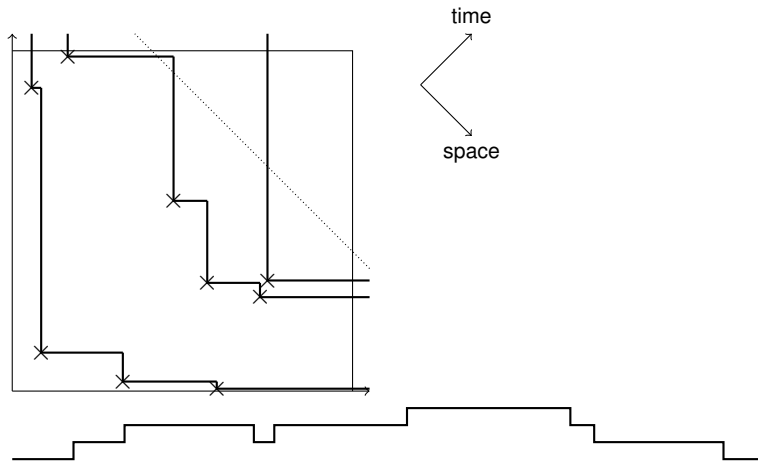

# Polynuclear Growth (PNG) [Hammersley '72]

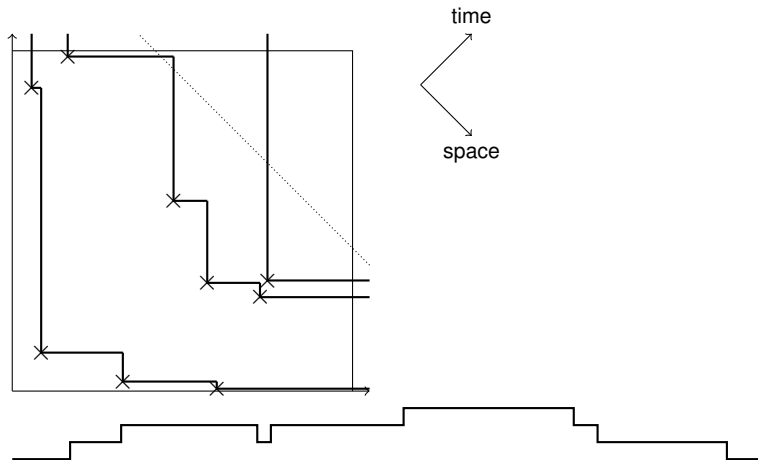

# Polynuclear Growth (PNG) [Hammersley '72]

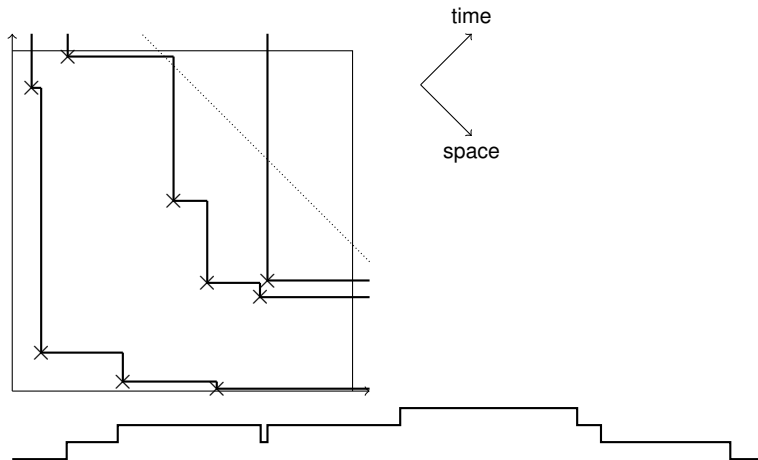

# Polynuclear Growth (PNG) [Hammersley '72]

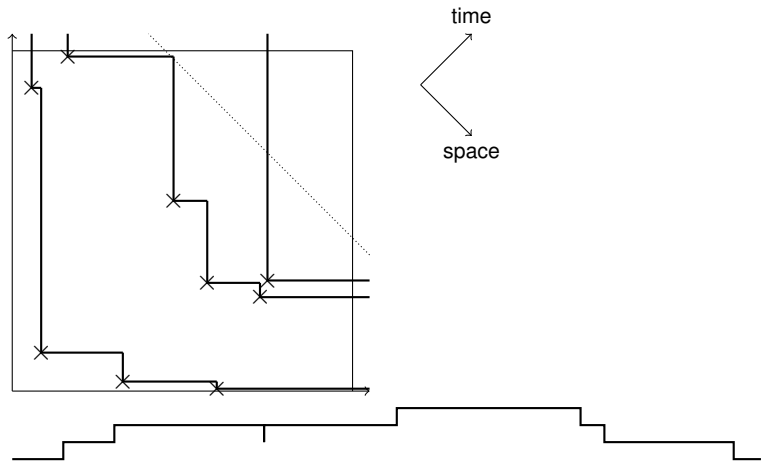

# Polynuclear Growth (PNG) [Hammersley '72]

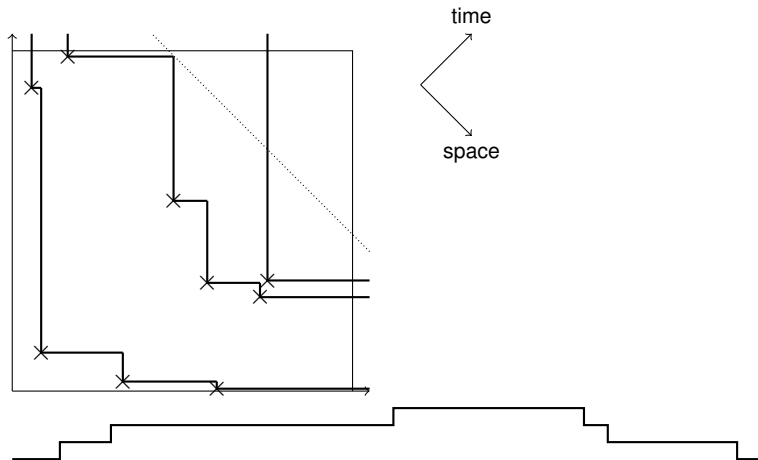

# Polynuclear Growth (PNG) [Hammersley '72]

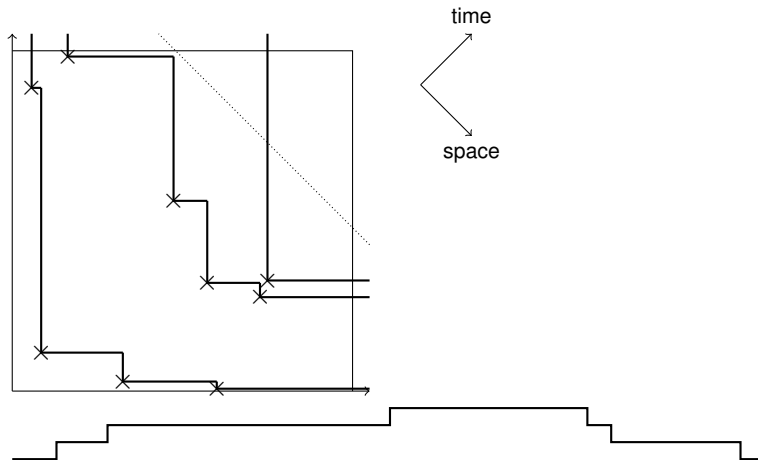

# Polynuclear Growth (PNG) [Hammersley '72]

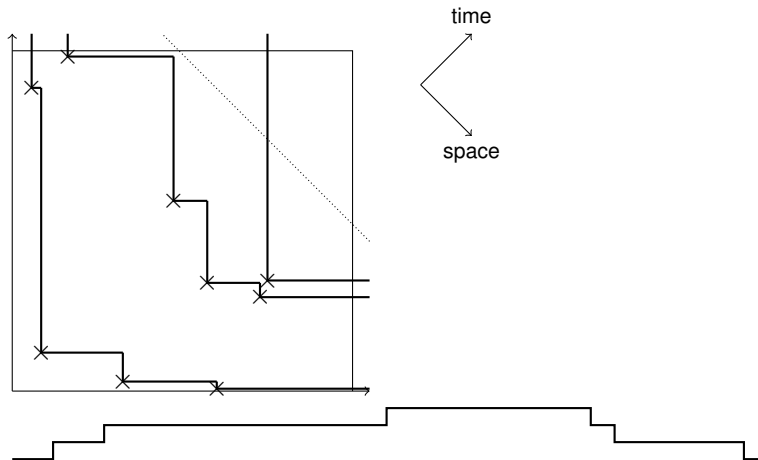



# Polynuclear Growth (PNG) [Hammersley '72]

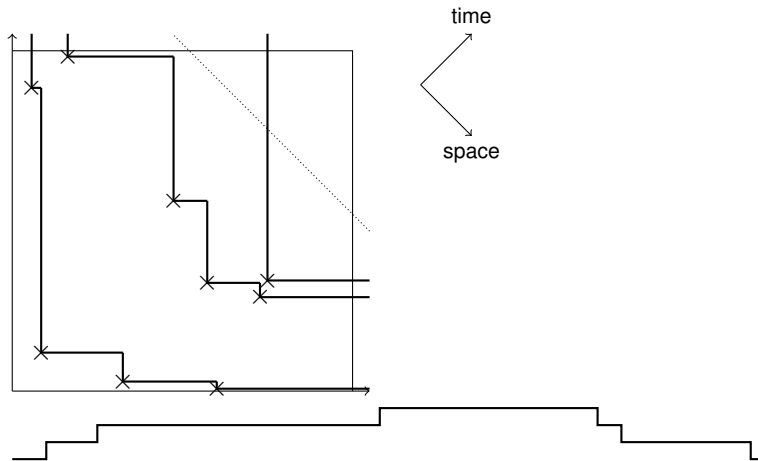

$t$ -PNG [Aggarwal, Borodin, Wheeler '23]

Flip coin: cross with prob.  $t$ , corner with prob.  $1 - t$ .

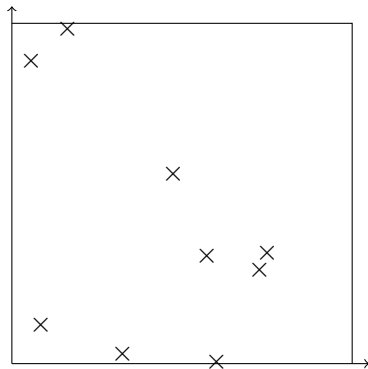

$t$ -PNG [Aggarwal, Borodin, Wheeler '23]

Flip coin: cross with prob.  $t$ , corner with prob.  $1 - t$ .

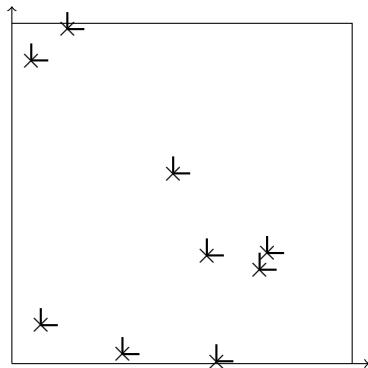

$t$ -PNG [Aggarwal, Borodin, Wheeler '23]

Flip coin: cross with prob.  $t$ , corner with prob.  $1 - t$ .

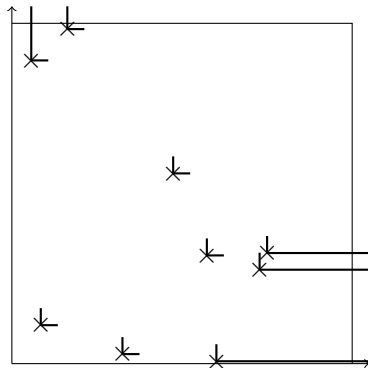





$t$ -PNG [Aggarwal, Borodin, Wheeler '23]

Flip coin: cross with prob.  $t$ , corner with prob.  $1 - t$ .

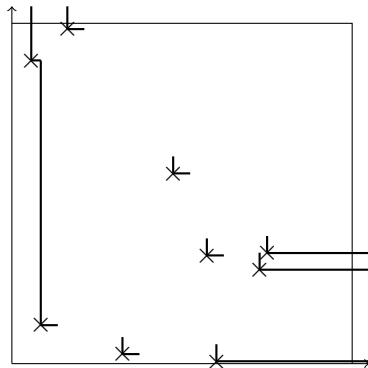

$t$ -PNG [Aggarwal, Borodin, Wheeler '23]

Flip coin: cross with prob.  $t$ , corner with prob.  $1 - t$ .

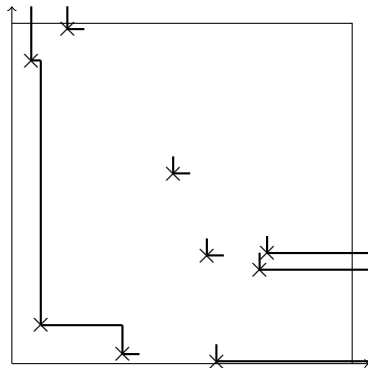

$t$ -PNG [Aggarwal, Borodin, Wheeler '23]

Flip coin: cross with prob.  $t$ , corner with prob.  $1 - t$ .

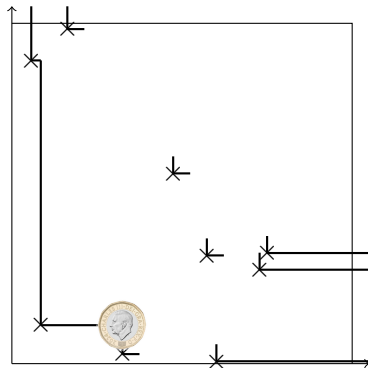

$t$ -PNG [Aggarwal, Borodin, Wheeler '23]

Flip coin: cross with prob.  $t$ , corner with prob.  $1 - t$ .

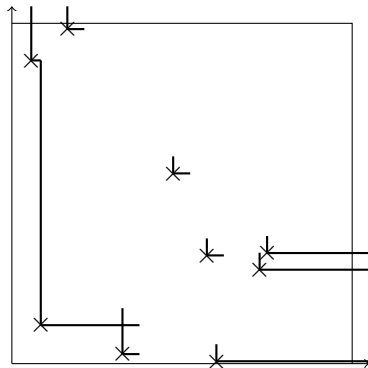



$t$ -PNG [Aggarwal, Borodin, Wheeler '23]

Flip coin: cross with prob.  $t$ , corner with prob.  $1 - t$ .

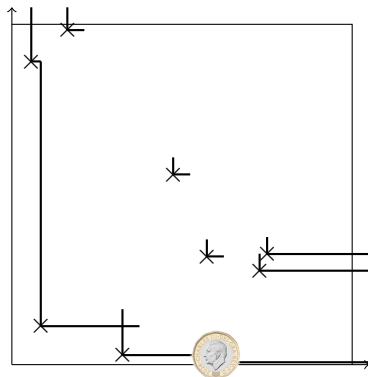





$t$ -PNG [Aggarwal, Borodin, Wheeler '23]

Flip coin: cross with prob.  $t$ , corner with prob.  $1 - t$ .

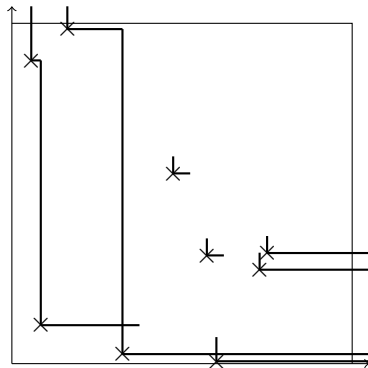





$t$ -PNG [Aggarwal, Borodin, Wheeler '23]

Flip coin: cross with prob.  $t$ , corner with prob.  $1 - t$ .

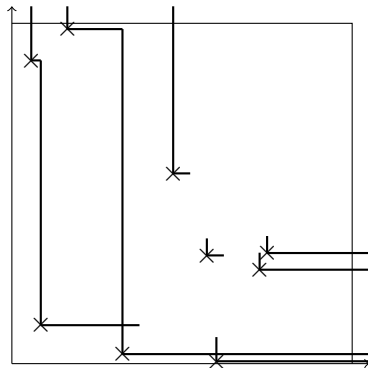

$t$ -PNG [Aggarwal, Borodin, Wheeler '23]

Flip coin: cross with prob.  $t$ , corner with prob.  $1 - t$ .

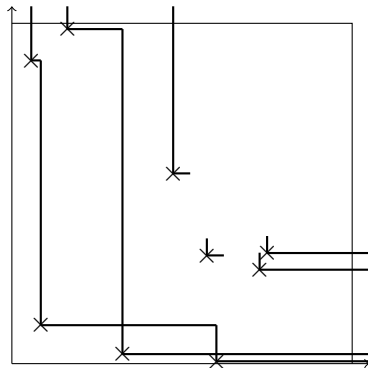



$t$ -PNG [Aggarwal, Borodin, Wheeler '23]

Flip coin: cross with prob.  $t$ , corner with prob.  $1 - t$ .

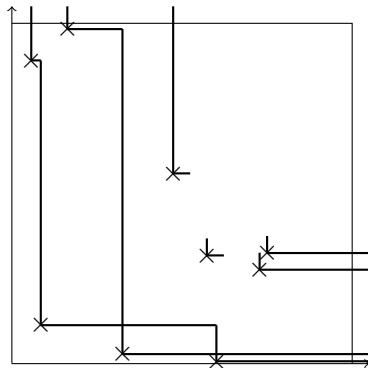

$t$ -PNG [Aggarwal, Borodin, Wheeler '23]

Flip coin: cross with prob.  $t$ , corner with prob.  $1 - t$ .

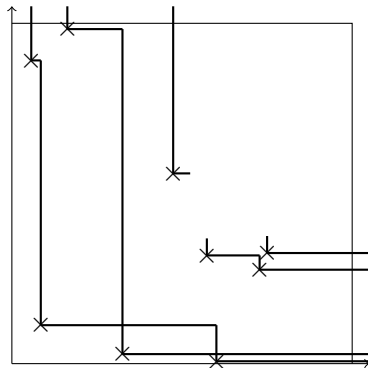



$t$ -PNG [Aggarwal, Borodin, Wheeler '23]

Flip coin: cross with prob.  $t$ , corner with prob.  $1 - t$ .

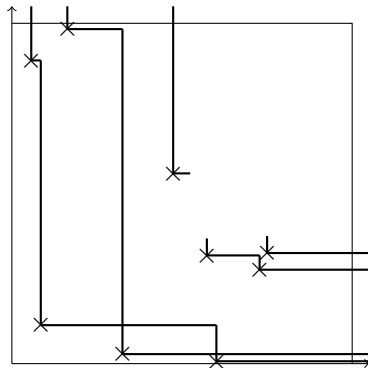





$t$ -PNG [Aggarwal, Borodin, Wheeler '23]

Flip coin: cross with prob.  $t$ , corner with prob.  $1 - t$ .

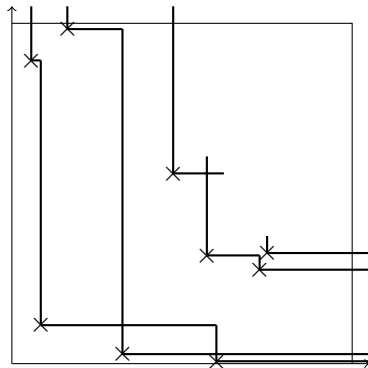

$t$ -PNG [Aggarwal, Borodin, Wheeler '23]

Flip coin: cross with prob.  $t$ , corner with prob.  $1 - t$ .

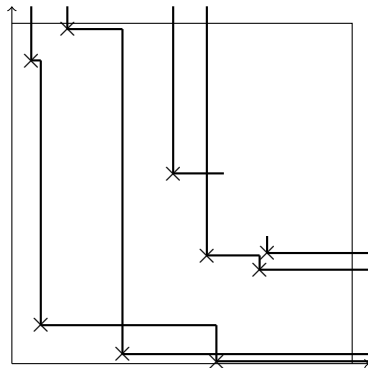

$t$ -PNG [Aggarwal, Borodin, Wheeler '23]

Flip coin: cross with prob.  $t$ , corner with prob.  $1 - t$ .

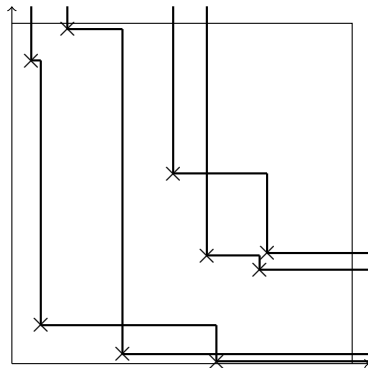

$t$ -PNG [Aggarwal, Borodin, Wheeler '23]

Flip coin: cross with prob.  $t$ , corner with prob.  $1 - t$ .

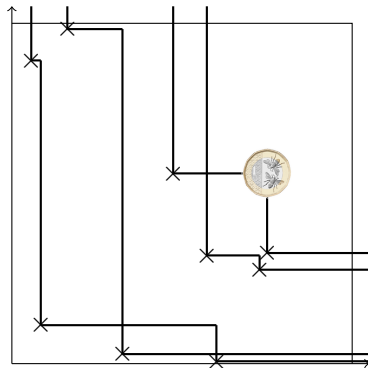

$t$ -PNG [Aggarwal, Borodin, Wheeler '23]

Flip coin: cross with prob.  $t$ , corner with prob.  $1 - t$ .

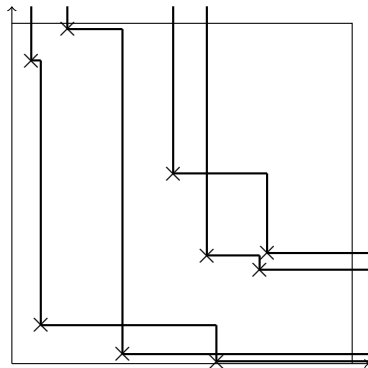



$t$ -PNG [Aggarwal, Borodin, Wheeler '23]

Flip coin: cross with prob.  $t$ , corner with prob.  $1 - t$ .

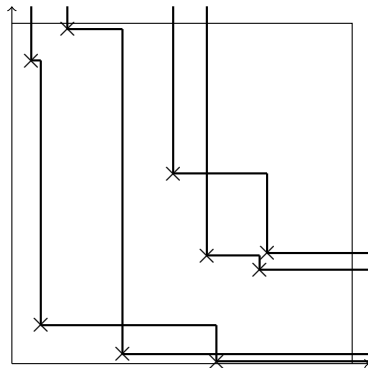

- ▶ Fluctuations: in KPZ-class [Aggarwal, Borodin, Wheeler '23]
- ▶ Colliding nucleations don't always annihilate (coin)

# Stationary $t$ -PNG [Drillick, Lin '24]

Flip coin: cross with prob.  $t$ , corner with prob.  $1 - t$ .

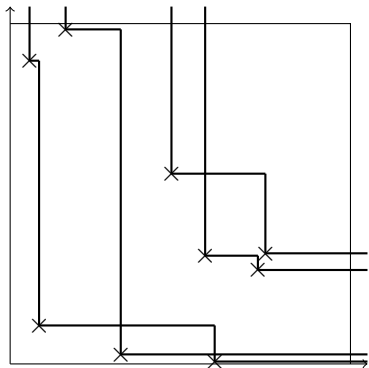

# Stationary $t$ -PNG [Drillick, Lin '24]

Flip coin: cross with prob.  $t$ , corner with prob.  $1 - t$ .

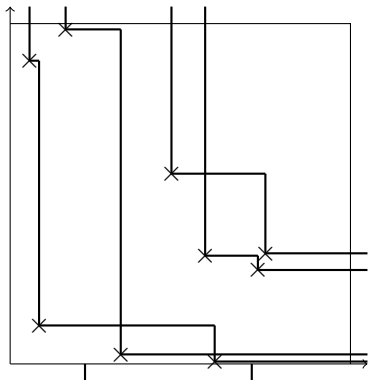

- Add **sources** on the bottom, and

# Stationary $t$ -PNG [Drillick, Lin '24]

Flip coin: cross with prob.  $t$ , corner with prob.  $1 - t$ .

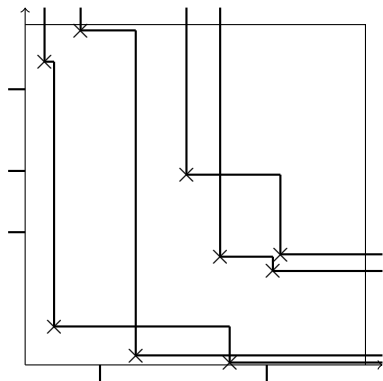

- ▶ Add **sources** on the bottom, and
- ▶ **sinks** on the left.

# Stationary $t$ -PNG [Drillick, Lin '24]

Flip coin: cross with prob.  $t$ , corner with prob.  $1 - t$ .

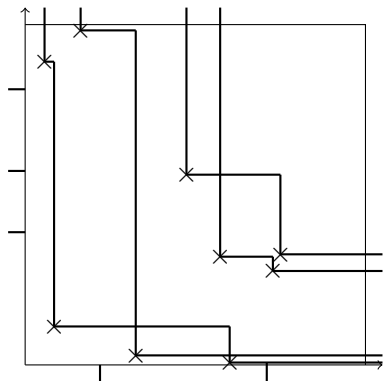

- ▶ Add **sources** on the bottom, and
- ▶ **sinks** on the left.

# Stationary $t$ -PNG [Drillick, Lin '24]

Flip coin: cross with prob.  $t$ , corner with prob.  $1 - t$ .

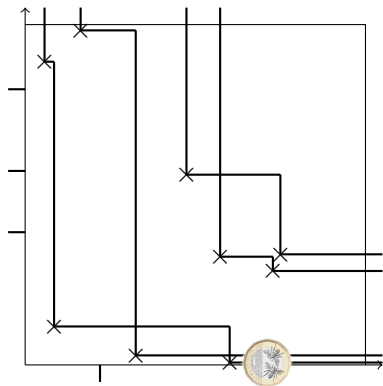

- ▶ Add **sources** on the bottom, and
- ▶ **sinks** on the left.

# Stationary $t$ -PNG [Drillick, Lin '24]

Flip coin: cross with prob.  $t$ , corner with prob.  $1 - t$ .

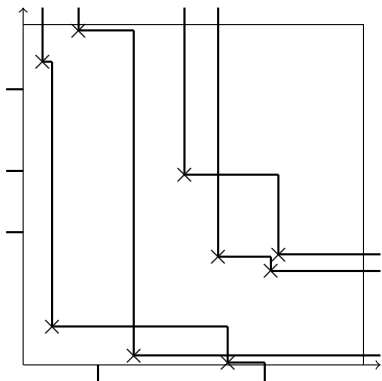

- ▶ Add **sources** on the bottom, and
- ▶ **sinks** on the left.

# Stationary $t$ -PNG [Drillick, Lin '24]

Flip coin: cross with prob.  $t$ , corner with prob.  $1 - t$ .

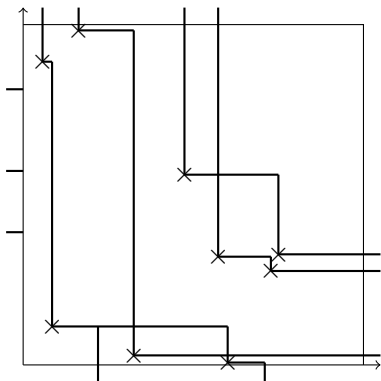

- ▶ Add **sources** on the bottom, and
- ▶ **sinks** on the left.

# Stationary $t$ -PNG [Drillick, Lin '24]

Flip coin: cross with prob.  $t$ , corner with prob.  $1 - t$ .

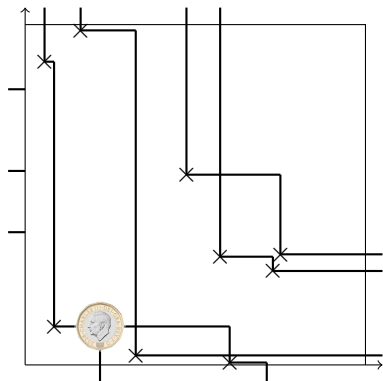

- ▶ Add **sources** on the bottom, and
- ▶ **sinks** on the left.

# Stationary $t$ -PNG [Drillick, Lin '24]

Flip coin: cross with prob.  $t$ , corner with prob.  $1 - t$ .

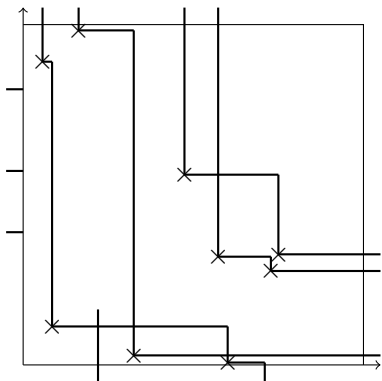

- ▶ Add **sources** on the bottom, and
- ▶ **sinks** on the left.

# Stationary $t$ -PNG [Drillick, Lin '24]

Flip coin: cross with prob.  $t$ , corner with prob.  $1 - t$ .

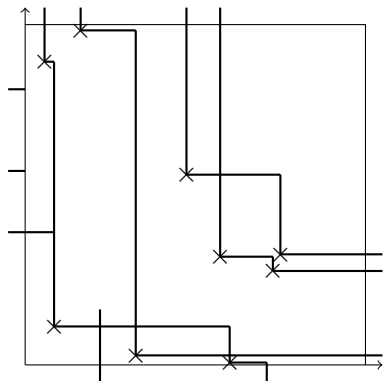

- ▶ Add **sources** on the bottom, and
- ▶ **sinks** on the left.

# Stationary $t$ -PNG [Drillick, Lin '24]

Flip coin: cross with prob.  $t$ , corner with prob.  $1 - t$ .

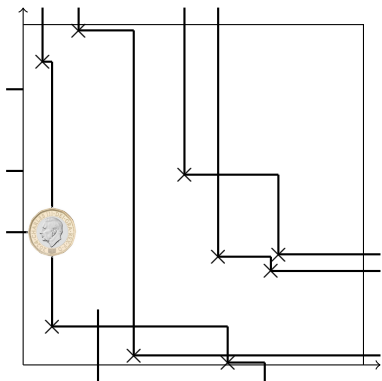

- ▶ Add **sources** on the bottom, and
- ▶ **sinks** on the left.

# Stationary $t$ -PNG [Drillick, Lin '24]

Flip coin: cross with prob.  $t$ , corner with prob.  $1 - t$ .

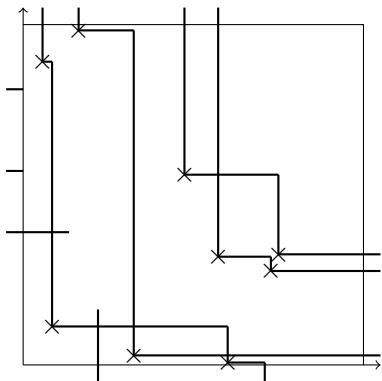

- ▶ Add **sources** on the bottom, and
- ▶ **sinks** on the left.

# Stationary $t$ -PNG [Drillick, Lin '24]

Flip coin: cross with prob.  $t$ , corner with prob.  $1 - t$ .

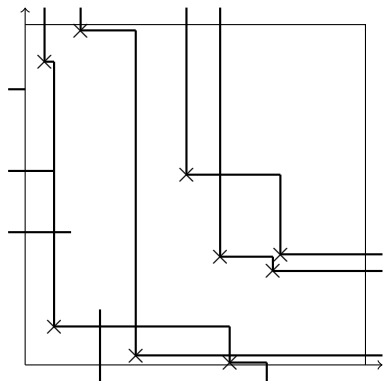

- ▶ Add **sources** on the bottom, and
- ▶ **sinks** on the left.

# Stationary $t$ -PNG [Drillick, Lin '24]

Flip coin: cross with prob.  $t$ , corner with prob.  $1 - t$ .

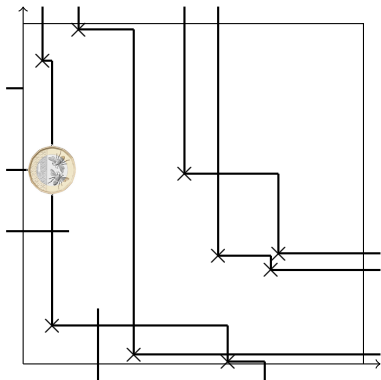

- ▶ Add **sources** on the bottom, and
- ▶ **sinks** on the left.

# Stationary $t$ -PNG [Drillick, Lin '24]

Flip coin: cross with prob.  $t$ , corner with prob.  $1 - t$ .

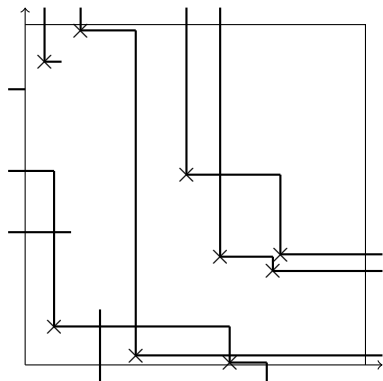

- ▶ Add **sources** on the bottom, and
- ▶ **sinks** on the left.

## Stationary $t$ -PNG [Drillick, Lin '24]

Flip coin: cross with prob.  $t$ , corner with prob.  $1 - t$ .

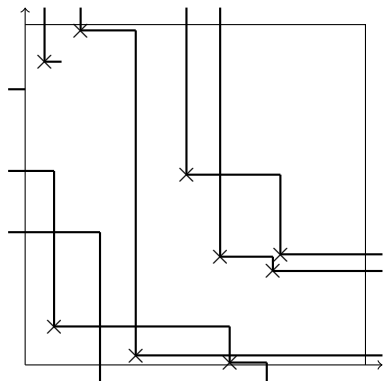

- ▶ Add **sources** on the bottom, and
- ▶ **sinks** on the left.

# Stationary $t$ -PNG [Drillick, Lin '24]

Flip coin: cross with prob.  $t$ , corner with prob.  $1 - t$ .

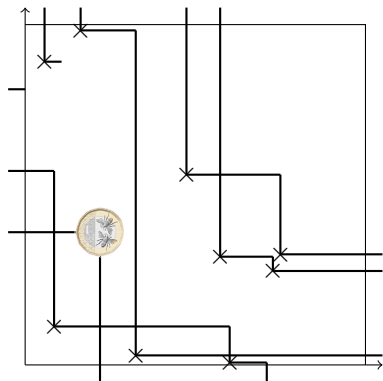

- ▶ Add **sources** on the bottom, and
- ▶ **sinks** on the left.

## Stationary $t$ -PNG [Drillick, Lin '24]

Flip coin: cross with prob.  $t$ , corner with prob.  $1 - t$ .

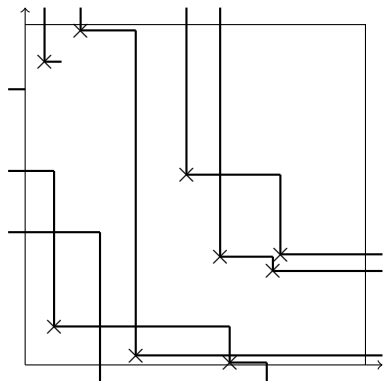

- ▶ Add **sources** on the bottom, and
- ▶ **sinks** on the left.

# Stationary $t$ -PNG [Drillick, Lin '24]

Flip coin: cross with prob.  $t$ , corner with prob.  $1 - t$ .

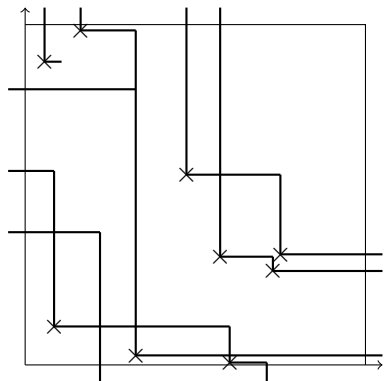

- ▶ Add **sources** on the bottom, and
- ▶ **sinks** on the left.



# Stationary $t$ -PNG [Drillick, Lin '24]

Flip coin: cross with prob.  $t$ , corner with prob.  $1 - t$ .

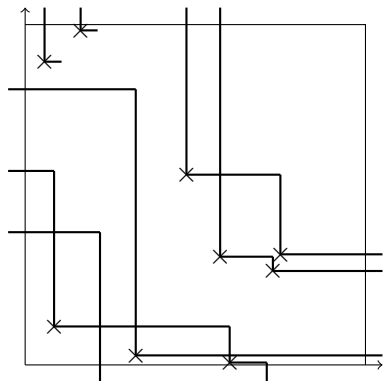

- ▶ Add **sources** on the bottom, and
- ▶ **sinks** on the left.

# Stationary $t$ -PNG [Drillick, Lin '24]

Flip coin: cross with prob.  $t$ , corner with prob.  $1 - t$ .

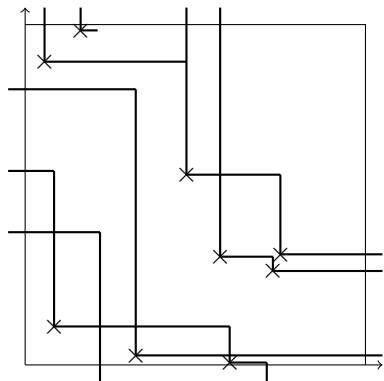

- ▶ Add **sources** on the bottom, and
- ▶ **sinks** on the left.

# Stationary $t$ -PNG [Drillick, Lin '24]

Flip coin: cross with prob.  $t$ , corner with prob.  $1 - t$ .

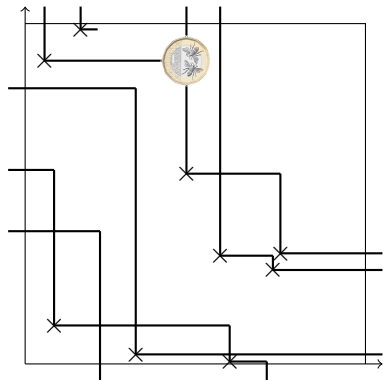

- ▶ Add **sources** on the bottom, and
- ▶ **sinks** on the left.

# Stationary $t$ -PNG [Drillick, Lin '24]

Flip coin: cross with prob.  $t$ , corner with prob.  $1 - t$ .

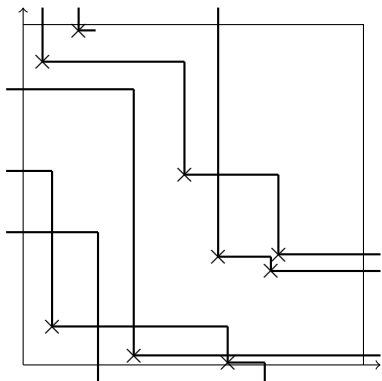

- ▶ Add **sources** on the bottom, and
- ▶ **sinks** on the left.

# Stationary $t$ -PNG [Drillick, Lin '24]

Flip coin: cross with prob.  $t$ , corner with prob.  $1 - t$ .

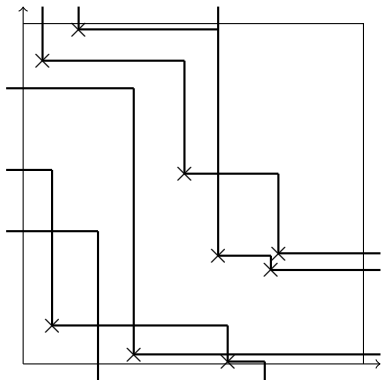

- ▶ Add **sources** on the bottom, and
- ▶ **sinks** on the left.

# Stationary $t$ -PNG [Drillick, Lin '24]

Flip coin: cross with prob.  $t$ , corner with prob.  $1 - t$ .

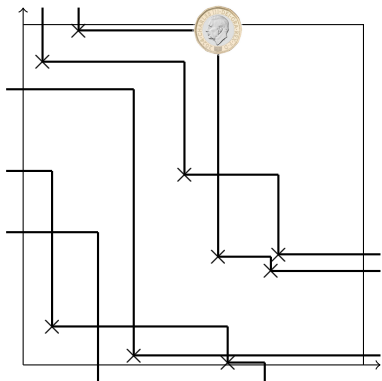

- ▶ Add **sources** on the bottom, and
- ▶ **sinks** on the left.

## Stationary $t$ -PNG [Drillick, Lin '24]

Flip coin: cross with prob.  $t$ , corner with prob.  $1 - t$ .

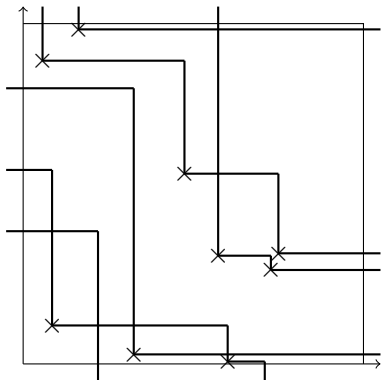

- ▶ Add **sources** on the bottom, and
- ▶ **sinks** on the left.

# Stationary $t$ -PNG [Drillick, Lin '24]

Flip coin: cross with prob.  $t$ , corner with prob.  $1 - t$ .

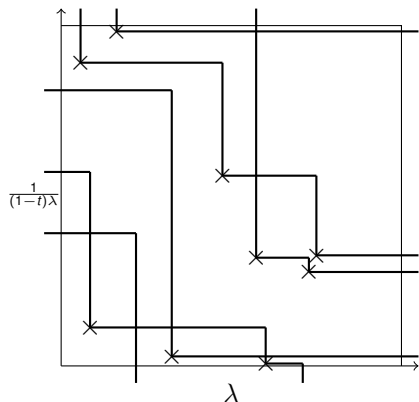

- ▶ Add **sources** on the bottom, and
- ▶ **sinks** on the left.

## Theorem

- ▶ If *sources*  $\sim \text{Poi}(\lambda)$ , and
- ▶ *sinks*  $\sim \text{Poi}(\frac{1}{(1-t)\lambda})$  independent,



# Stationary $t$ -PNG [Drillick, Lin '24]

Flip coin: cross with prob.  $t$ , corner with prob.  $1 - t$ .

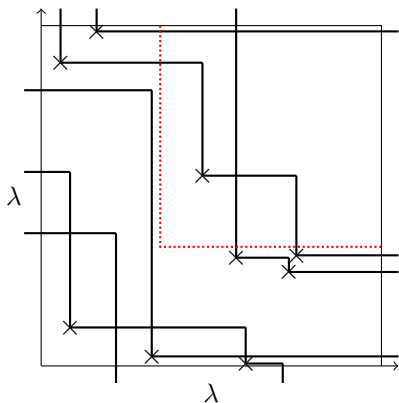

- ▶ Add **sources** on the bottom, and
- ▶ **sinks** on the left.

## Theorem

- ▶ If *sources*  $\sim \text{Poi}(\lambda)$ , and
- ▶ *sinks*  $\sim \text{Poi}(\frac{1}{(1-t)\lambda})$  independent,

then lines entering 

- ▶ on the bottom  $\sim \text{Poi}(\lambda)$
- ▶ on the left  $\sim \text{Poi}(\frac{1}{(1-t)\lambda})$ , independent.

# Local convergence

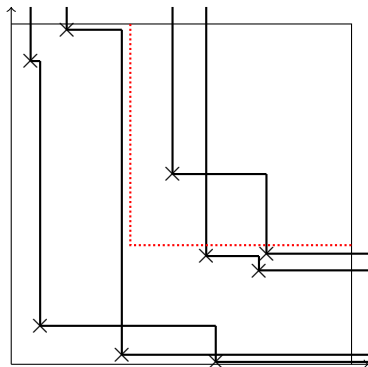

# Local convergence

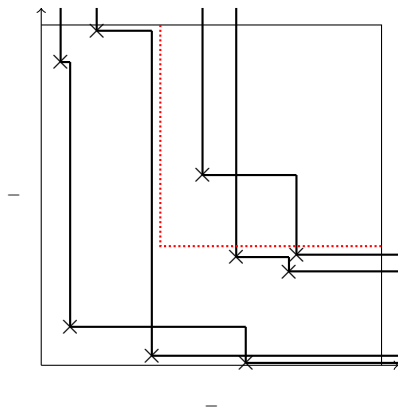

# Local convergence

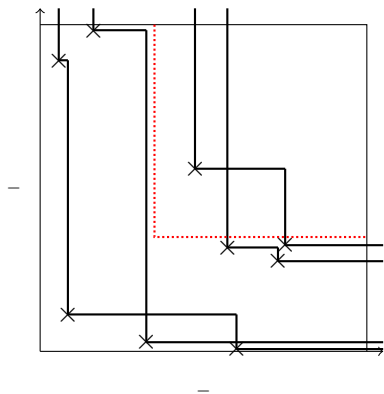

# Local convergence

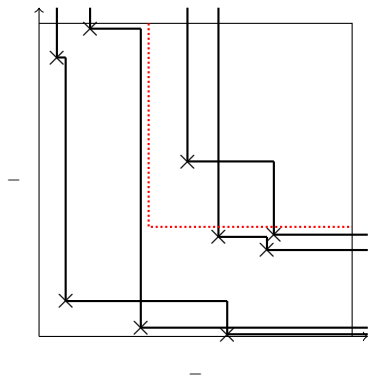

# Local convergence

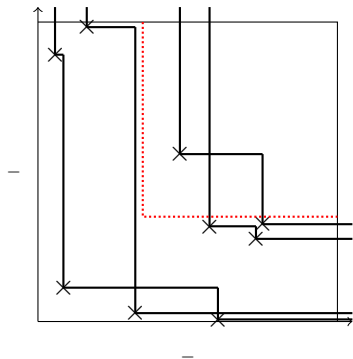

# Local convergence

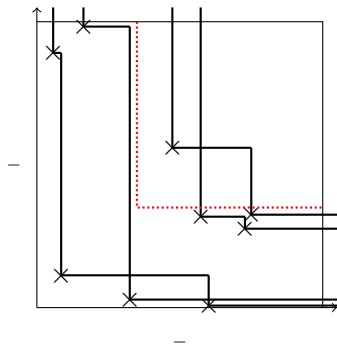

# Local convergence

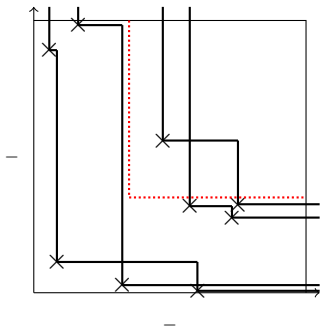

# Local convergence

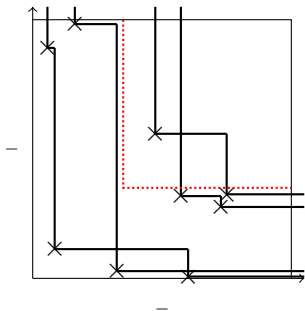

# Local convergence

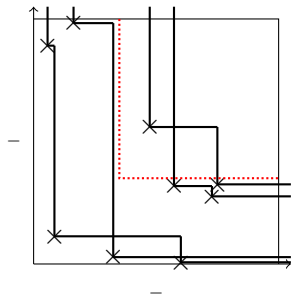

# Local convergence

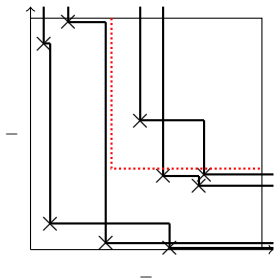

# Local convergence

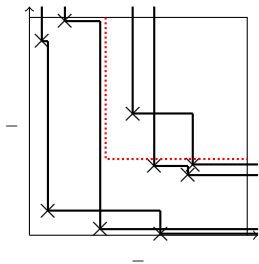

# Local convergence

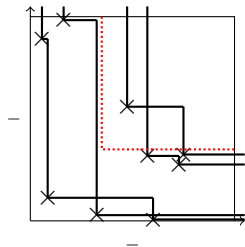

# Local convergence

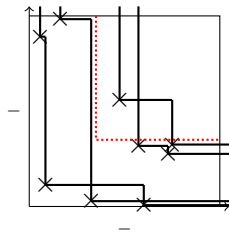

# Local convergence

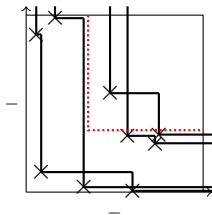

# Local convergence

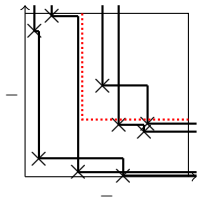

# Local convergence

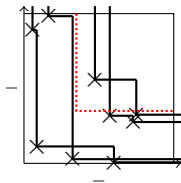

# Local convergence

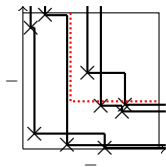

# Local convergence

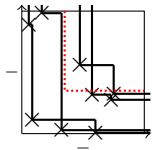

# Local convergence

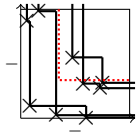

# Local convergence

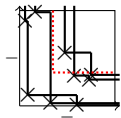

# Local convergence



# Local convergence

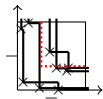

# Local convergence

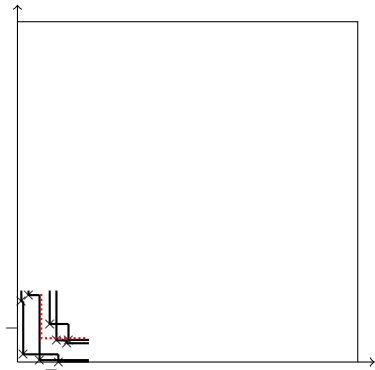

# Local convergence

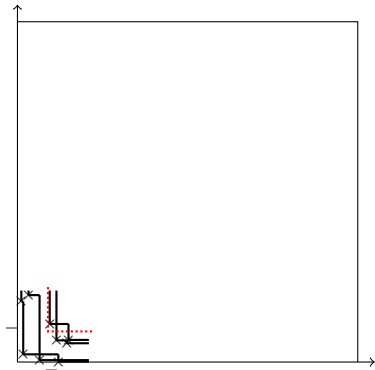

# Local convergence

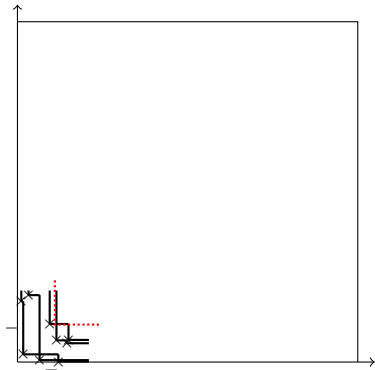

# Local convergence

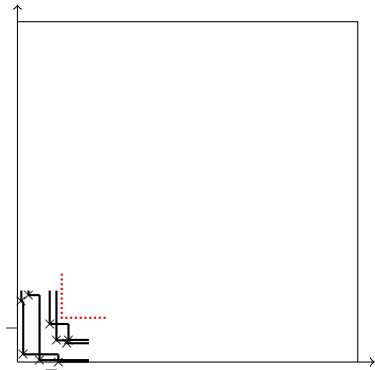

# Local convergence

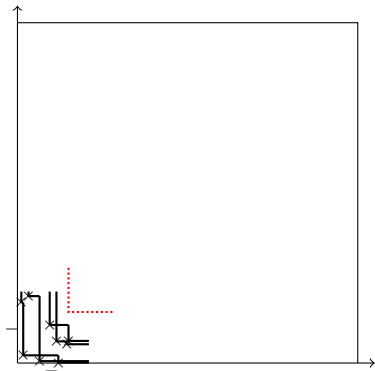

# Local convergence

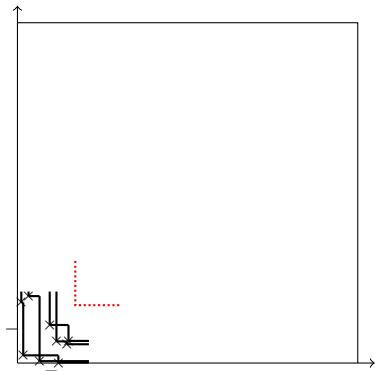

# Local convergence

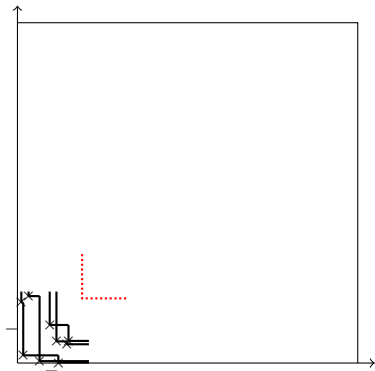

# Local convergence

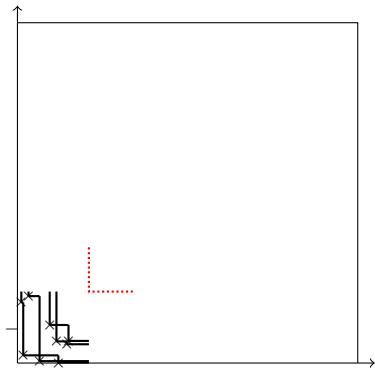

# Local convergence

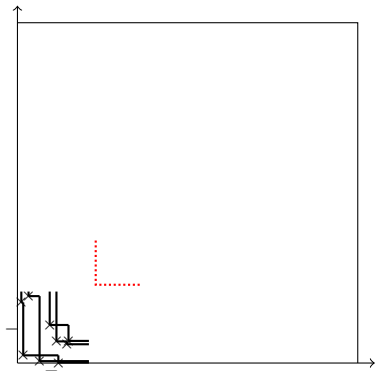

# Local convergence

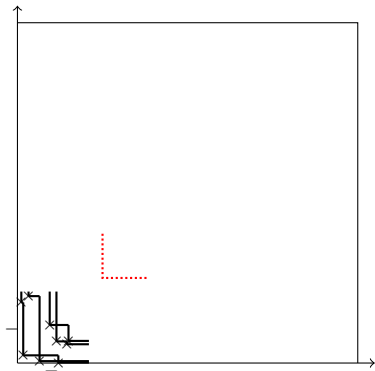

# Local convergence

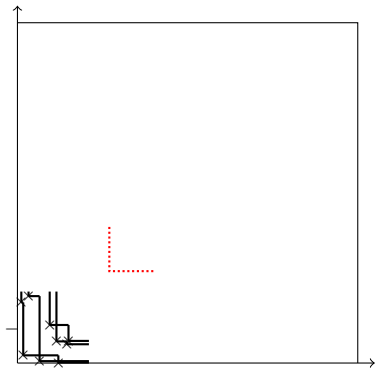

# Local convergence

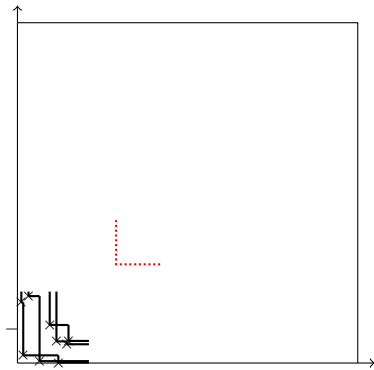

# Local convergence

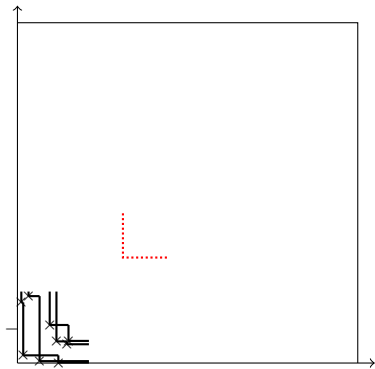

# Local convergence

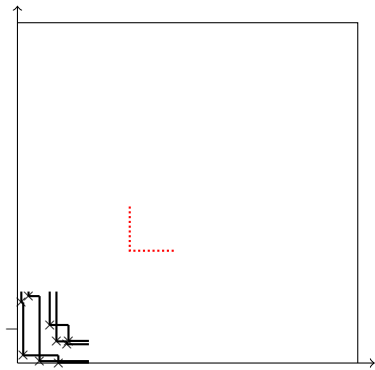

# Local convergence

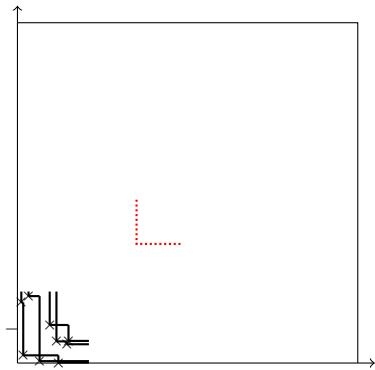

# Local convergence

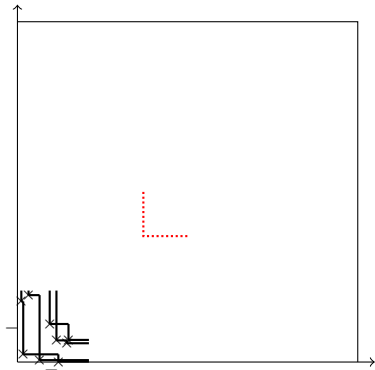

# Local convergence

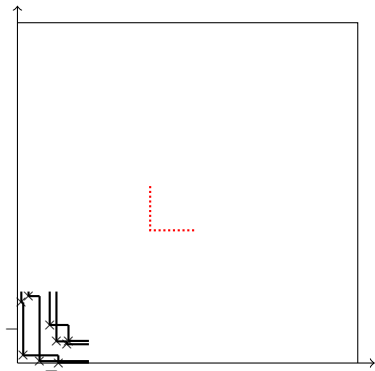

# Local convergence

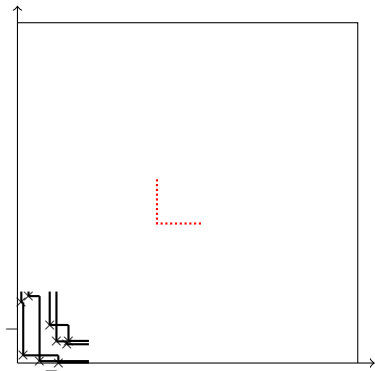

# Local convergence

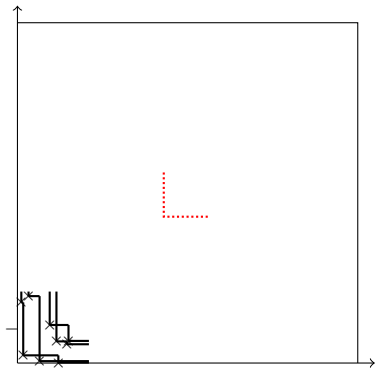

# Local convergence

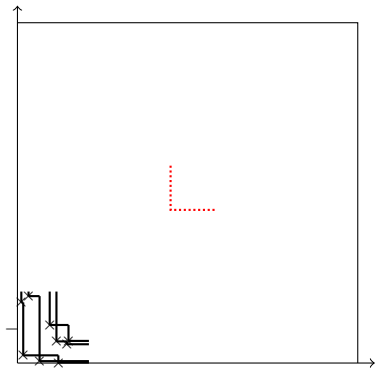

# Local convergence

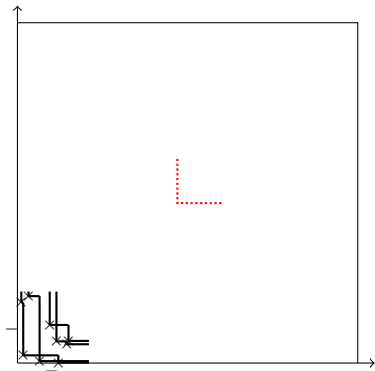

# Local convergence

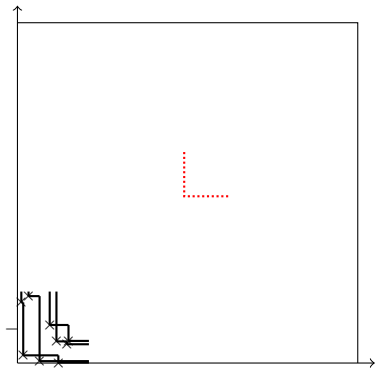

# Local convergence

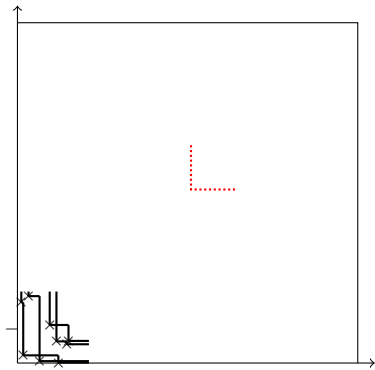

# Local convergence

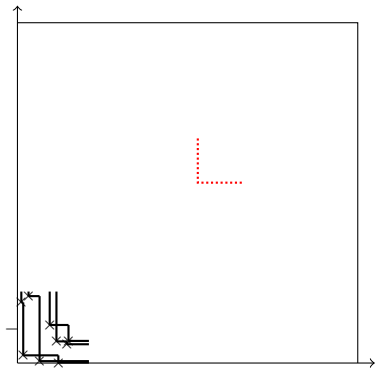

# Local convergence

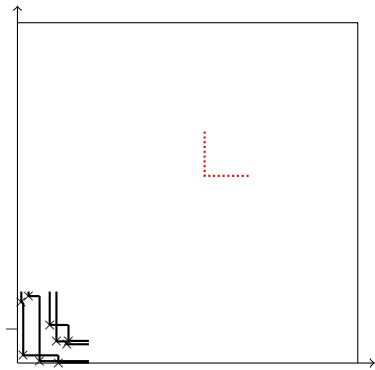

# Local convergence

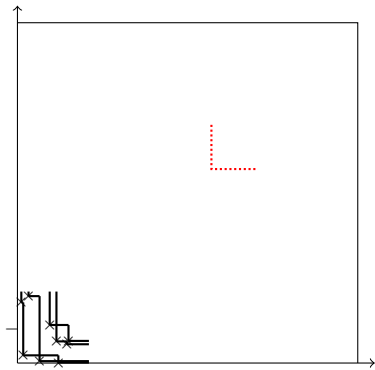

# Local convergence

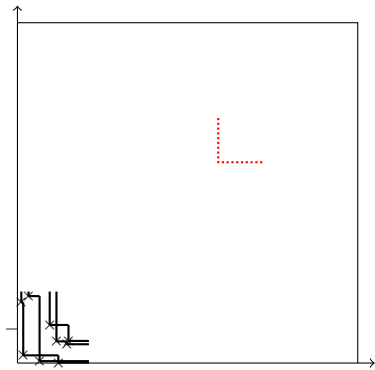

# Local convergence

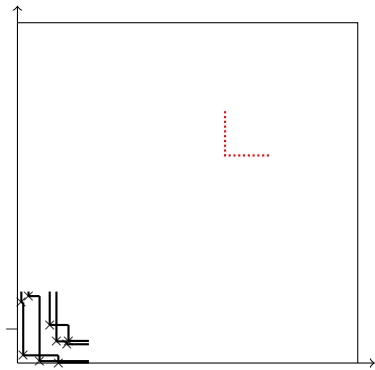

# Local convergence

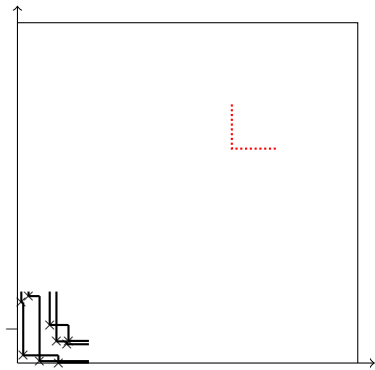

# Local convergence

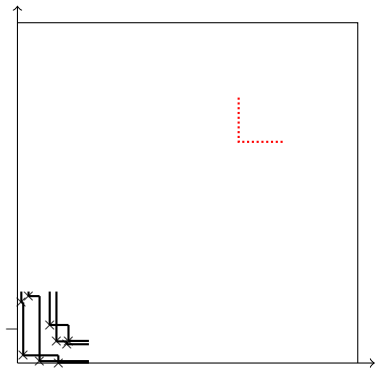

# Local convergence

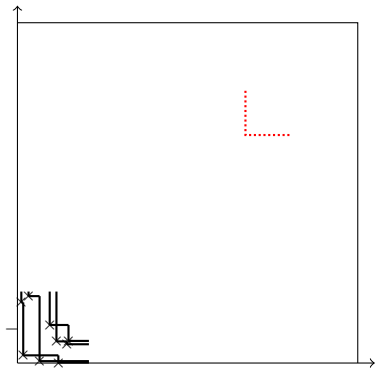

# Local convergence

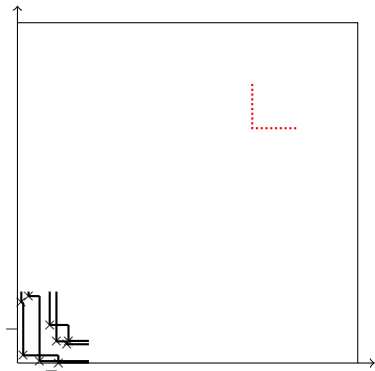

# Local convergence

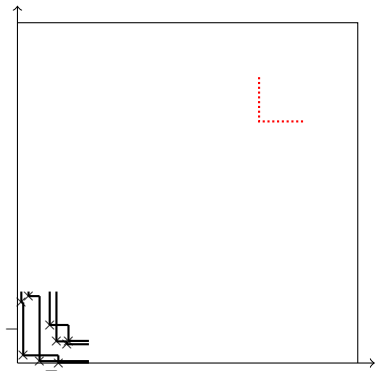

# Local convergence

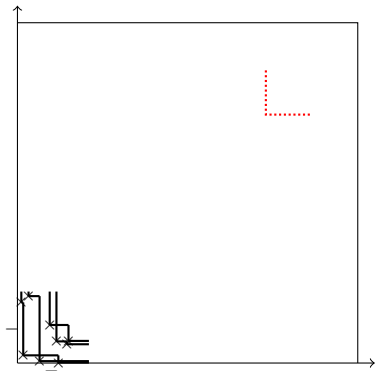

# Local convergence

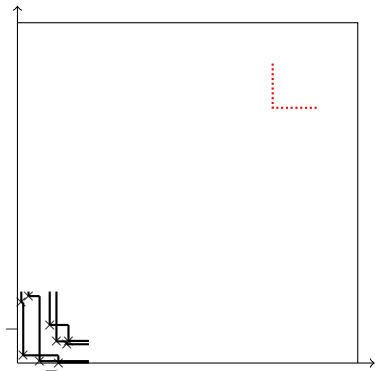

# Local convergence

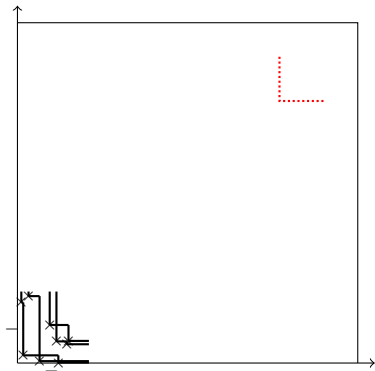

# Local convergence

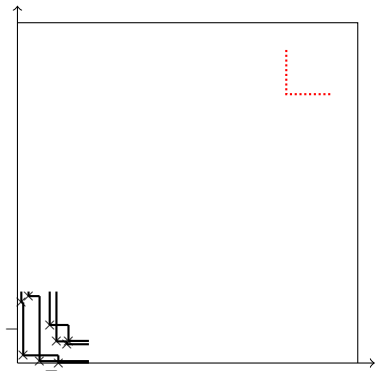

# Local convergence

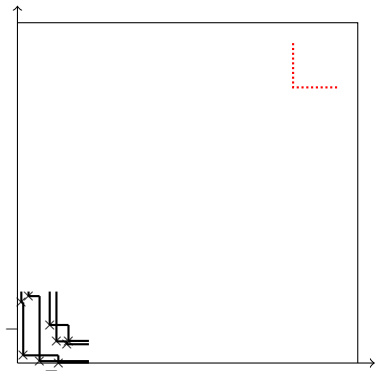

# Local convergence

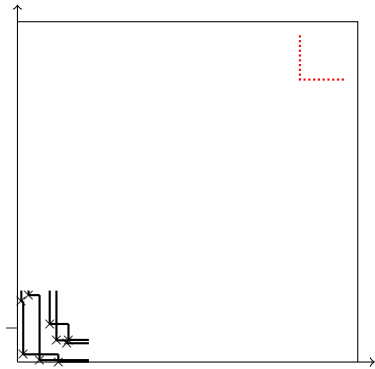

# Local convergence

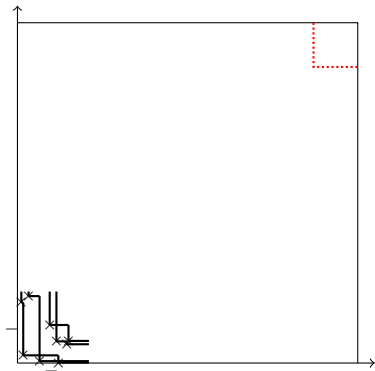

# Local convergence

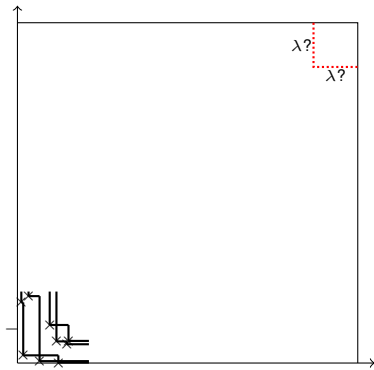

# Local convergence

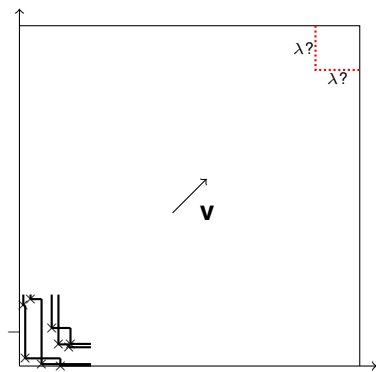

# Local convergence

## Theorem

*Yes, the boundaries of the small box converge in distribution to the two independent stationary Poisson processes with an explicit  $\lambda = \lambda(\mathbf{v})$  (*direction*).*

# Local convergence

## Theorem

*Yes, the boundaries of the small box converge in distribution to the two independent stationary Poisson processes with an explicit  $\lambda = \lambda(\mathbf{v})$  (*direction*).*

- ▶ Confirms the conjecture from [Drillick, Lin '24].

# Local convergence

## Theorem

*Yes, the boundaries of the small box converge in distribution to the two independent stationary Poisson processes with an explicit  $\lambda = \lambda(\mathbf{v})$  (*direction*).*

- ▶ Confirms the conjecture from [Drillick, Lin '24].
- ▶ Hence the full  $t$ -PNG inside the small box converges to stationary  $t$ -PNG.

# Local convergence

## Theorem

*Yes, the boundaries of the small box converge in distribution to the two independent stationary Poisson processes with an explicit  $\lambda = \lambda(\mathbf{v})$  (direction).*

- ▶ Confirms the conjecture from [Drillick, Lin '24].
- ▶ Hence the full  $t$ -PNG inside the small box converges to stationary  $t$ -PNG.
- ▶ The actual limit intensities are  $\frac{1}{\sqrt{1-t}} \sqrt{\frac{v_2}{v_1}}$  for sources and  $\frac{1}{\sqrt{1-t}} \sqrt{\frac{v_1}{v_2}}$  for sinks.

## Shape theorem [Drillick, Lin '24]

Define  $L_x :=$  no. of lines entering the bottom or right edge.

Then  $L_x =$  no. of lines exiting the left or top edge.

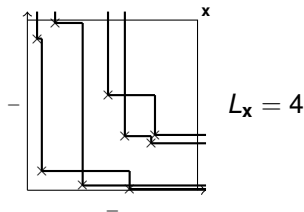

## Shape theorem [Drillick, Lin '24]

Define  $L_{\mathbf{x}}$  := no. of lines entering the bottom or right edge.

Then  $L_{\mathbf{x}} =$  no. of lines exiting the left or top edge.

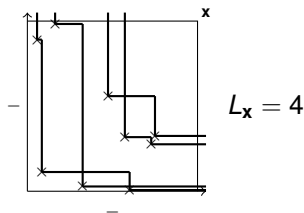

## Theorem

*With zero boundaries,*

$$\lim_{\mathbf{x} \rightarrow \infty} \frac{L_{\mathbf{x}}}{|\mathbf{x}|} = 2 \sqrt{\frac{v_1 v_2}{|\mathbf{v}|^2 \cdot (1-t)}}.$$

# Second class particles

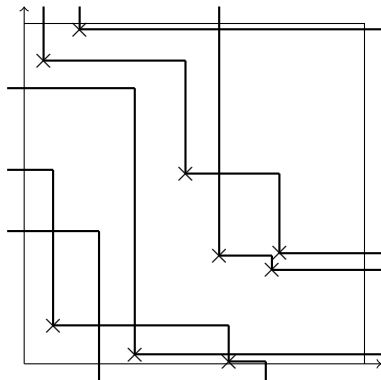
 $\alpha$

## Second class particles

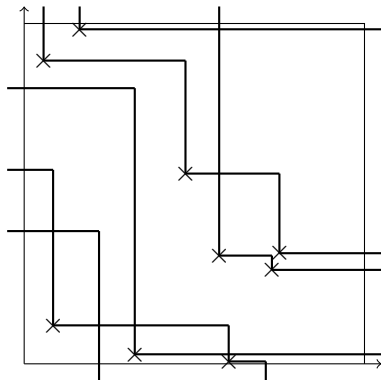

Definition:  $\alpha \leq \omega$ , if

- ▶ more verticals in  $\omega$ ,
- ▶ more horizontals in  $\alpha$ .

## Second class particles

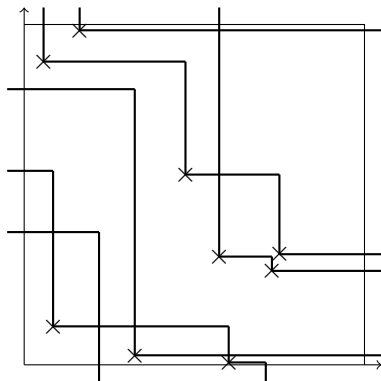

Definition:  $\alpha \leq \omega$ , if

- ▶ more verticals in  $\omega$ ,
- ▶ more horizontals in  $\alpha$ .
- ▶ (less horizontals in  $\omega$ .)

## Second class particles

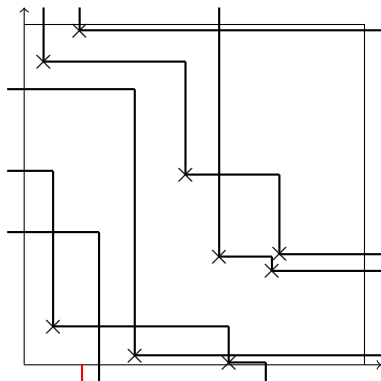

Definition:  $\alpha \leq \omega$ , if

- ▶ more verticals in  $\omega$ ,
- ▶ more horizontals in  $\alpha$ .
- ▶ (less horizontals in  $\omega$ .)

## Second class particles

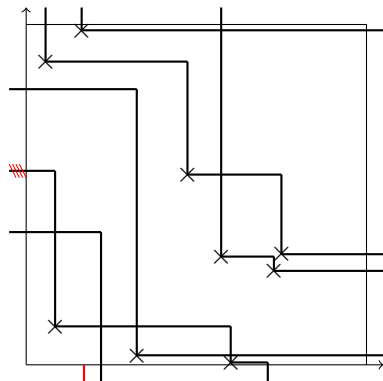

Definition:  $\alpha \leq \omega$ , if

- ▶ more verticals in  $\omega$ ,
- ▶ more horizontals in  $\alpha$ .
- ▶ (less horizontals in  $\omega$ .)

## Second class particles

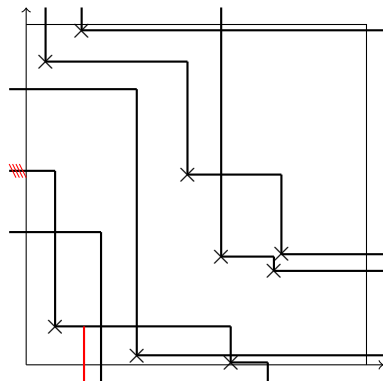

Definition:  $\alpha \leq \omega$ , if

- ▶ more verticals in  $\omega$ ,
- ▶ more horizontals in  $\alpha$ .
- ▶ (less horizontals in  $\omega$ .)

## Second class particles

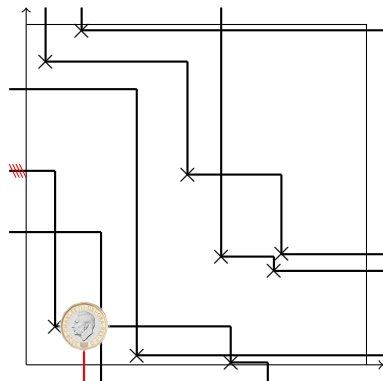

Definition:  $\alpha \leq \omega$ , if

- ▶ more verticals in  $\omega$ ,
- ▶ more horizontals in  $\alpha$ .
- ▶ (less horizontals in  $\omega$ .)

## Second class particles

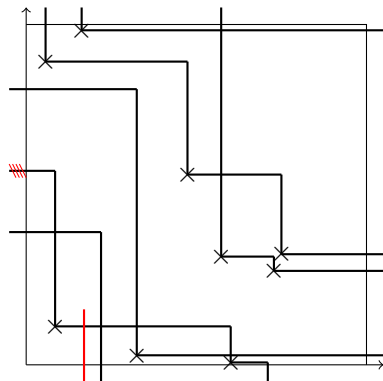

Definition:  $\alpha \leq \omega$ , if

- ▶ more verticals in  $\omega$ ,
- ▶ more horizontals in  $\alpha$ .
- ▶ (less horizontals in  $\omega$ .)

## Second class particles

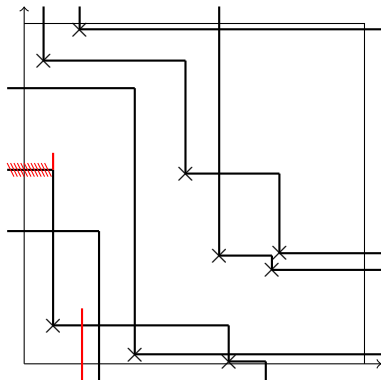

Definition:  $\alpha \leq \omega$ , if

- ▶ more verticals in  $\omega$ ,
- ▶ more horizontals in  $\alpha$ .
- ▶ (less horizontals in  $\omega$ .)

## Second class particles

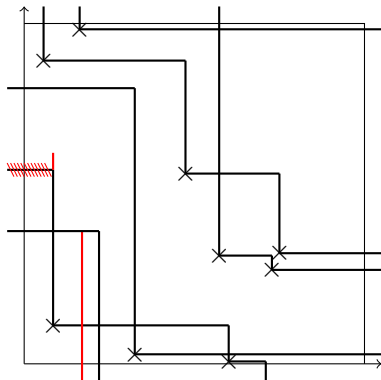

Definition:  $\alpha \leq \omega$ , if

- ▶ more verticals in  $\omega$ ,
- ▶ more horizontals in  $\alpha$ .
- ▶ (less horizontals in  $\omega$ .)

## Second class particles

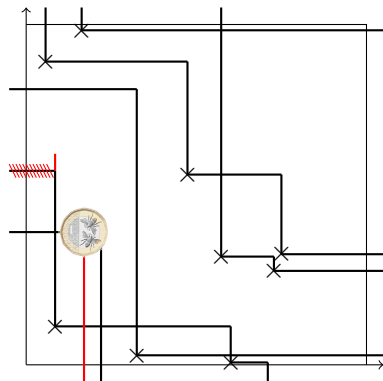

Definition:  $\alpha \leq \omega$ , if

- ▶ more verticals in  $\omega$ ,
- ▶ more horizontals in  $\alpha$ .
- ▶ (less horizontals in  $\omega$ .)

## Second class particles

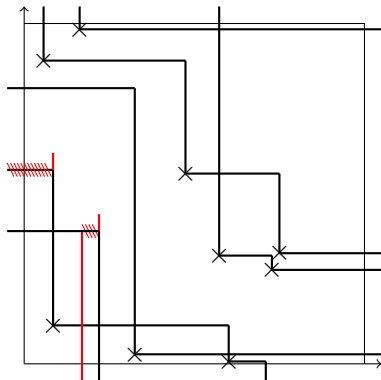

Definition:  $\alpha \leq \omega$ , if

- ▶ more verticals in  $\omega$ ,
- ▶ more horizontals in  $\alpha$ .
- ▶ (less horizontals in  $\omega$ .)

## Second class particles

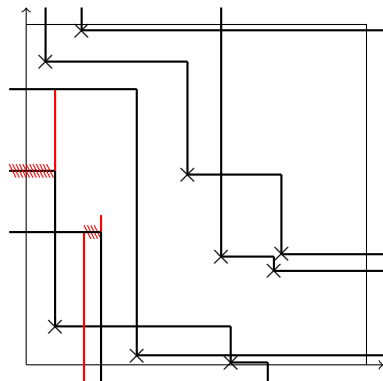

Definition:  $\alpha \leq \omega$ , if

- ▶ more verticals in  $\omega$ ,
- ▶ more horizontals in  $\alpha$ .
- ▶ (less horizontals in  $\omega$ .)

## Second class particles

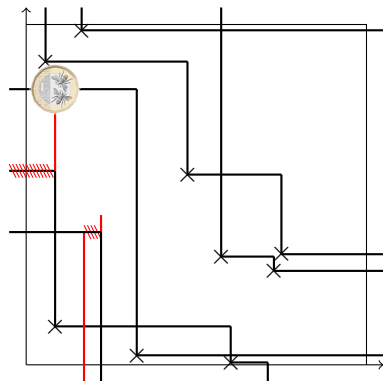

Definition:  $\alpha \leq \omega$ , if

- ▶ more verticals in  $\omega$ ,
- ▶ more horizontals in  $\alpha$ .
- ▶ (less horizontals in  $\omega$ .)

## Second class particles

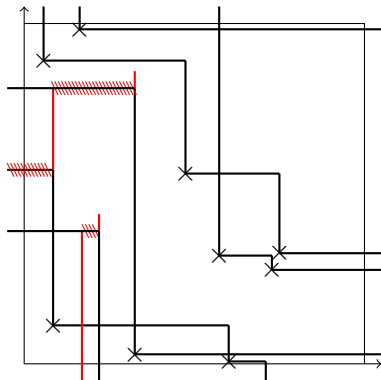

Definition:  $\alpha \leq \omega$ , if

- ▶ more verticals in  $\omega$ ,
- ▶ more horizontals in  $\alpha$ .
- ▶ (less horizontals in  $\omega$ .)

## Second class particles

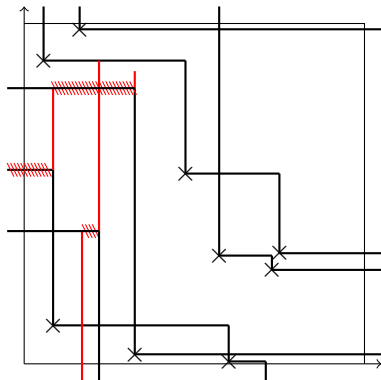

Definition:  $\alpha \leq \omega$ , if

- ▶ more verticals in  $\omega$ ,
- ▶ more horizontals in  $\alpha$ .
- ▶ (less horizontals in  $\omega$ .)

## Second class particles

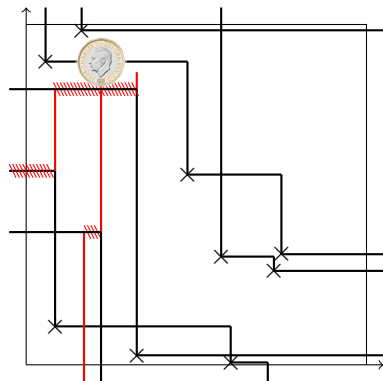

Definition:  $\alpha \leq \omega$ , if

- ▶ more verticals in  $\omega$ ,
- ▶ more horizontals in  $\alpha$ .
- ▶ (less horizontals in  $\omega$ .)

## Second class particles

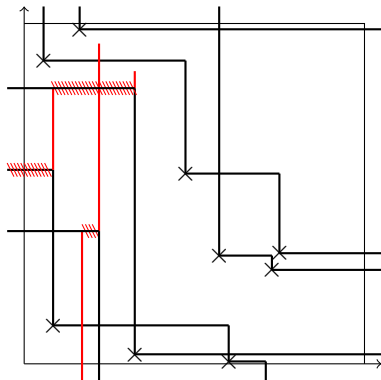

Definition:  $\alpha \leq \omega$ , if

- ▶ more verticals in  $\omega$ ,
- ▶ more horizontals in  $\alpha$ .
- ▶ (less horizontals in  $\omega$ .)

## Second class particles

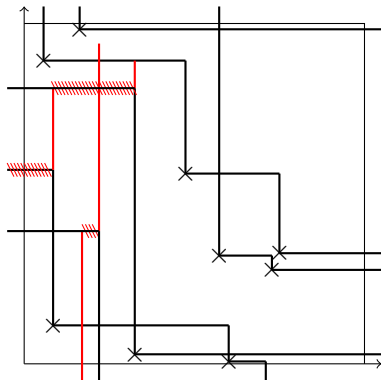

Definition:  $\alpha \leq \omega$ , if

- ▶ more verticals in  $\omega$ ,
- ▶ more horizontals in  $\alpha$ .
- ▶ (less horizontals in  $\omega$ .)





## Second class particles

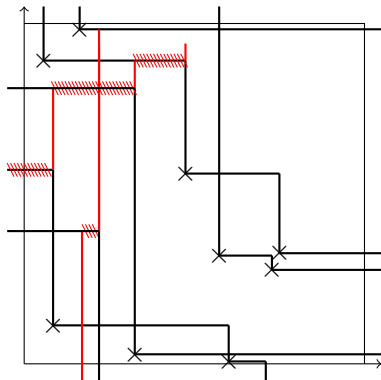

Definition:  $\alpha \leq \omega$ , if

- ▶ more verticals in  $\omega$ ,
- ▶ more horizontals in  $\alpha$ .
- ▶ (less horizontals in  $\omega$ .)

## Second class particles

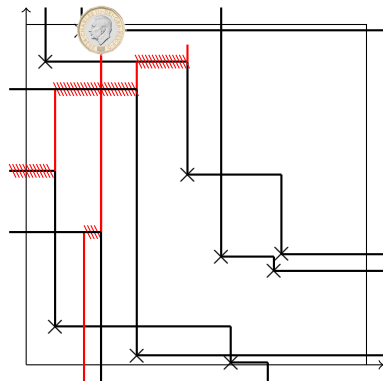

Definition:  $\alpha \leq \omega$ , if

- ▶ more verticals in  $\omega$ ,
- ▶ more horizontals in  $\alpha$ .
- ▶ (less horizontals in  $\omega$ .)





## Second class particles

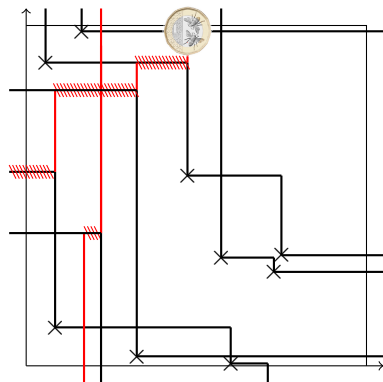

Definition:  $\alpha \leq \omega$ , if

- ▶ more verticals in  $\omega$ ,
- ▶ more horizontals in  $\alpha$ .
- ▶ (less horizontals in  $\omega$ .)

## Second class particles

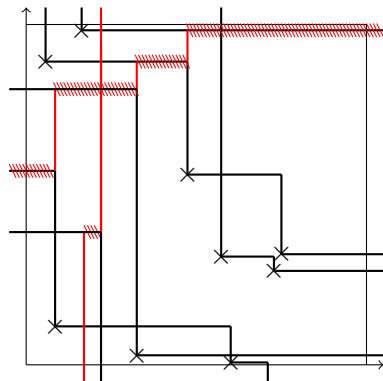

Definition:  $\alpha \leq \omega$ , if

- ▶ more verticals in  $\omega$ ,
- ▶ more horizontals in  $\alpha$ .
- ▶ (less horizontals in  $\omega$ .)



# Second class particles

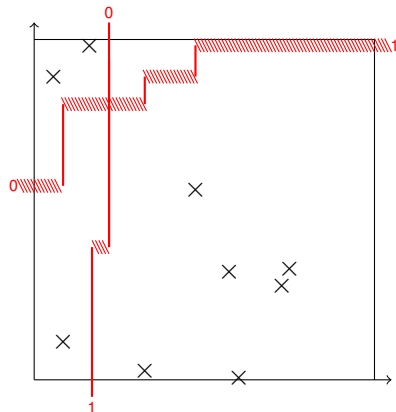

Definition:  $\alpha \leq \omega$ , if

- ▶ more verticals in  $\omega$ ,
- ▶ more horizontals in  $\alpha$ .
- ▶ (less horizontals in  $\omega$ .)

$\frac{\alpha}{\omega}$  second class particles:  
upright paths  
that stay ordered

# Second class particles

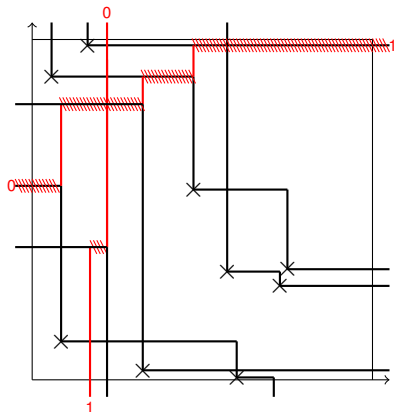

Definition:  $\alpha \leq \omega$ , if

- ▶ more verticals in  $\omega$ ,
- ▶ more horizontals in  $\alpha$ .
- ▶ (less horizontals in  $\omega$ .)

$\frac{\omega}{\alpha}$  second class particles:  
upright paths  
that stay ordered

## Second class particles

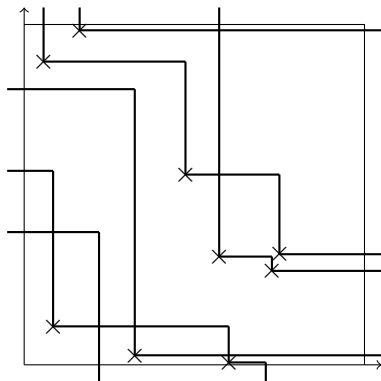

Definition:  $\alpha \leq \omega$ , if

- ▶ more verticals in  $\omega$ ,
- ▶ more horizontals in  $\alpha$ .
- ▶ (less horizontals in  $\omega$ .)

$\frac{\omega}{\alpha}$  second class particles:  
upright paths  
that stay ordered

# Second class particles

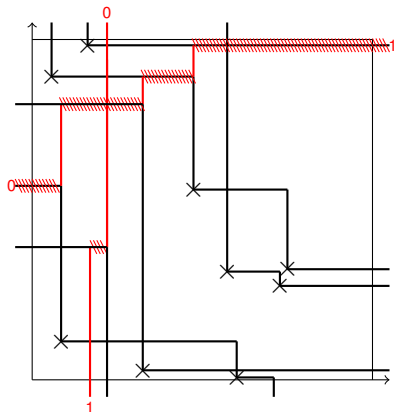

Definition:  $\alpha \leq \omega$ , if

- ▶ more verticals in  $\omega$ ,
- ▶ more horizontals in  $\alpha$ .
- ▶ (less horizontals in  $\omega$ .)

$\frac{\omega}{\alpha}$  second class particles:  
upright paths  
that stay ordered

## Second class particles

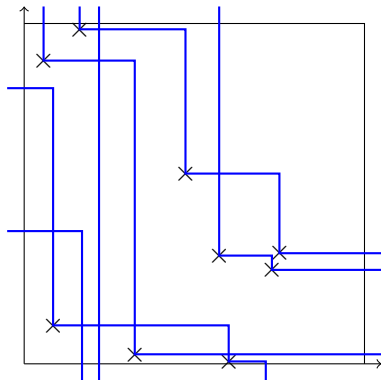

Definition:  $\alpha \leq \omega$ , if

- ▶ more verticals in  $\omega$ ,
- ▶ more horizontals in  $\alpha$ .
- ▶ (less horizontals in  $\omega$ .)

$\frac{\alpha}{\omega}$  second class particles:  
upright paths  
that stay ordered

## The main actors

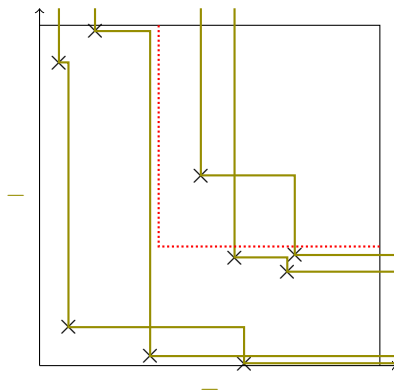

WTS: lines crossing  $\rightarrow$   
 $\text{stati}(\lambda(\mathbf{v}))$  Poisson

$\theta^{-,-}$

# The main actors

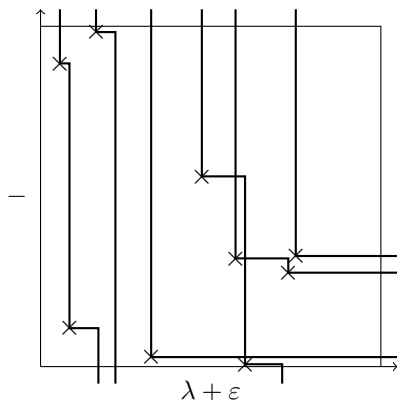

WTS: lines crossing   $\rightarrow$   
 $\text{stati}(\lambda(\mathbf{v}))$  Poisson

$$\theta^{-,-} \leq \omega^{\lambda+\epsilon,-}$$

$$\omega^{\lambda+\epsilon,-}$$

# The main actors

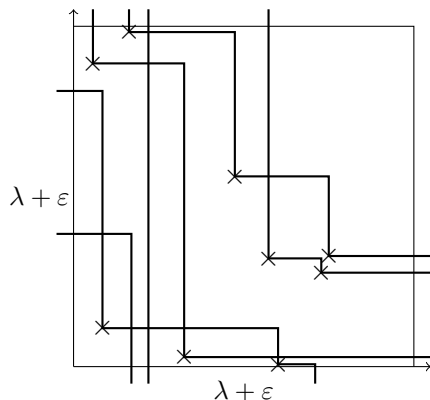

WTS: lines crossing  $\llcorner$   $\rightarrow$   
 $\text{stati}(\lambda(\mathbf{v}))$  Poisson

$$\theta^{-,-} \leq \omega^{\lambda+\epsilon,-}$$

$$\omega^{\lambda+\epsilon,-} \geq \eta^{\lambda+\epsilon,\lambda+\epsilon}$$

# The main actors

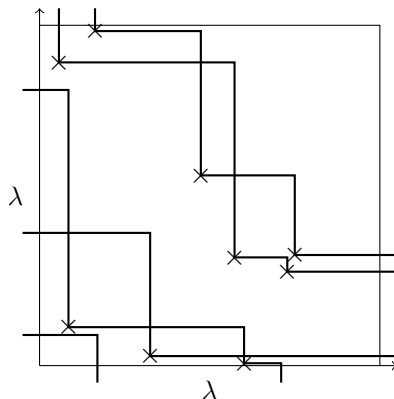

WTS: lines crossing  $\llcorner$   $\rightarrow$   
 $\text{stati}(\lambda(\mathbf{v}))$  Poisson

$$\theta^{-,-} \leq \omega^{\lambda+\varepsilon,-}$$

$$\omega^{\lambda+\varepsilon,-} \geq \eta^{\lambda+\varepsilon,\lambda+\varepsilon} \geq \alpha^{\lambda,\lambda}$$

# The main actors

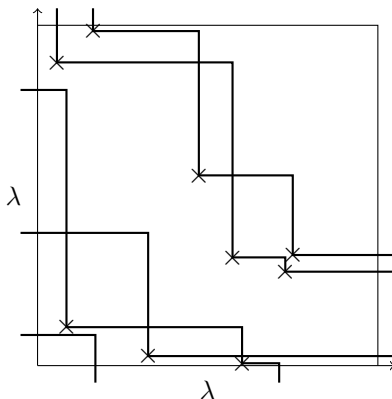

WTS: lines crossing  $\begin{array}{c} \text{---} \\ | \\ \text{---} \end{array} \rightarrow$   
 $\text{stati}(\lambda(\mathbf{v}))$  Poisson

$$\theta^{-,-} \leq \omega^{\lambda+\varepsilon,-}$$

$$\omega^{\lambda+\varepsilon,-} \geq \eta^{\lambda+\varepsilon,\lambda+\varepsilon} \geq \alpha^{\lambda,\lambda}$$

---

$$\theta^{-,-} \leq \omega^{\lambda+\varepsilon,-} \geq \eta^{\lambda+\varepsilon,\lambda+\varepsilon} \geq \alpha^{\lambda,\lambda}$$

# 1. $\frac{\omega^{\lambda+\varepsilon,-}}{\alpha^{\lambda,\lambda}}$ 2nd class particles and the small box

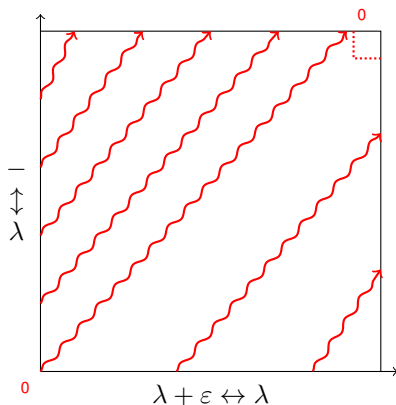

Second class particle 0 goes above the small box.

---

$$\theta^{-,-} \leq \underline{\omega^{\lambda+\varepsilon,-}} \geq \underline{\eta^{\lambda+\varepsilon,\lambda+\varepsilon}} \geq \underline{\alpha^{\lambda,\lambda}}$$

# 1. $\frac{\omega^{\lambda+\varepsilon,-}}{\alpha^{\lambda,\lambda}}$ 2nd class particles and the small box

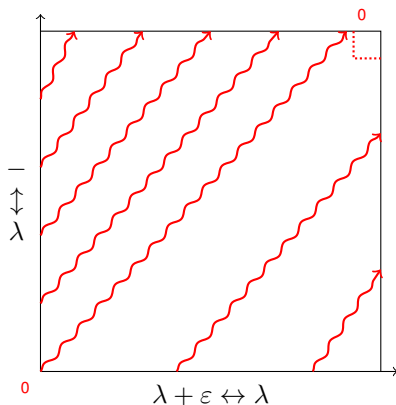

Second class particle 0 goes above the small box.

That's because of the shape thm for each  $\omega^{\lambda+\varepsilon,-}$  and  $\alpha^{\lambda,\lambda}$ ,

and the  $\varepsilon$  leeway.

$$\theta^{-,-} \leq \underline{\omega^{\lambda+\varepsilon,-}} \geq \underline{\eta^{\lambda+\varepsilon,\lambda+\varepsilon}} \geq \underline{\alpha^{\lambda,\lambda}}$$

2.  $\frac{\omega^{\lambda+\varepsilon,-}}{\eta^{\lambda+\varepsilon,\lambda+\varepsilon}}$  on  $\frac{\omega^{\lambda+\varepsilon,-}}{\alpha^{\lambda,\lambda}}$

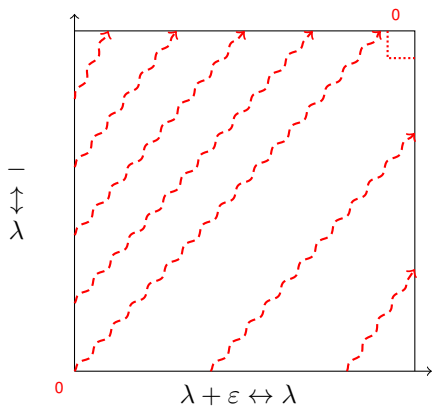

---

$$\theta^{-,-} \leq \underline{\omega^{\lambda+\varepsilon,-}} \geq \underline{\eta^{\lambda+\varepsilon,\lambda+\varepsilon}} \geq \underline{\alpha^{\lambda,\lambda}}$$

2.  $\frac{\omega^{\lambda+\varepsilon,-}}{\eta^{\lambda+\varepsilon,\lambda+\varepsilon}}$  on  $\frac{\omega^{\lambda+\varepsilon,-}}{\alpha^{\lambda,\lambda}}$

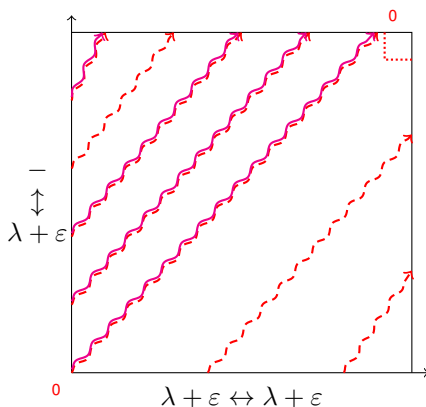

$$\left\{ \frac{\omega^{\lambda+\varepsilon,-}}{\eta^{\lambda+\varepsilon,\lambda+\varepsilon}} \right\} \subseteq \left\{ \frac{\omega^{\lambda+\varepsilon,-}}{\alpha^{\lambda,\lambda}} \right\}$$

and only start from the left boundary.

---

$$\theta^{-,-} \leq \underline{\omega^{\lambda+\varepsilon,-}} \geq \eta^{\lambda+\varepsilon,\lambda+\varepsilon} \geq \alpha^{\lambda,\lambda}$$

2.  $\frac{\omega^{\lambda+\varepsilon,-}}{\eta^{\lambda+\varepsilon,\lambda+\varepsilon}}$  on  $\frac{\omega^{\lambda+\varepsilon,-}}{\alpha^{\lambda,\lambda}}$

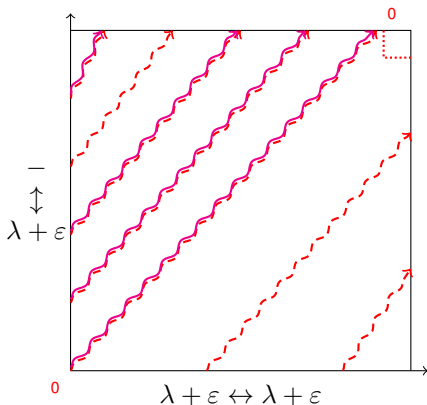

$$\left\{ \frac{\omega^{\lambda+\varepsilon,-}}{\eta^{\lambda+\varepsilon,\lambda+\varepsilon}} \right\} \subseteq \left\{ \frac{\omega^{\lambda+\varepsilon,-}}{\alpha^{\lambda,\lambda}} \right\}$$

and only start from the left boundary.

$\rightsquigarrow$  there is a rightmost  $\frac{\omega^{\lambda+\varepsilon,-}}{\eta^{\lambda+\varepsilon,\lambda+\varepsilon}}$  second class particle, jumping on  $\left\{ \frac{\omega^{\lambda+\varepsilon,-}}{\alpha^{\lambda,\lambda}} \right\}$ .

---

$$\theta^{-,-} \leq \underline{\omega^{\lambda+\varepsilon,-}} \geq \underline{\eta^{\lambda+\varepsilon,\lambda+\varepsilon}} \geq \alpha^{\lambda,\lambda}$$

3.  $\frac{\omega^{\lambda+\varepsilon,-}}{\eta^{\lambda+\varepsilon,\lambda+\varepsilon}}$  on  $\frac{\omega^{\lambda+\varepsilon,-}}{\alpha^{\lambda,\lambda}}$ : we have drift!

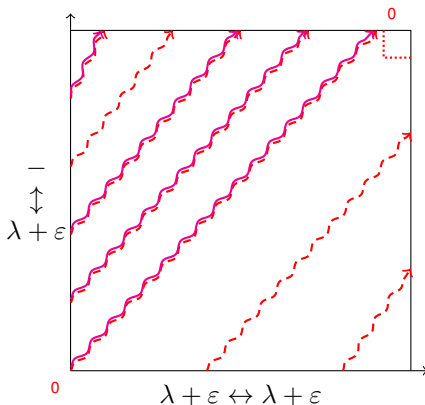

$$\left\{ \frac{\omega^{\lambda+\varepsilon,-}}{\eta^{\lambda+\varepsilon,\lambda+\varepsilon}} \right\} \subseteq \left\{ \frac{\omega^{\lambda+\varepsilon,-}}{\alpha^{\lambda,\lambda}} \right\}$$

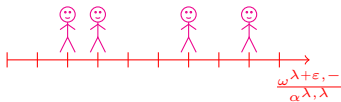

↪: prob. 1

↪: prob.  $t$

$$\theta^{-,-} \leq \frac{\omega^{\lambda+\varepsilon,-}}{\eta^{\lambda+\varepsilon,\lambda+\varepsilon}} \geq \alpha^{\lambda,\lambda}$$

3.  $\frac{\omega^{\lambda+\varepsilon,-}}{\eta^{\lambda+\varepsilon,\lambda+\varepsilon}}$  on  $\frac{\omega^{\lambda+\varepsilon,-}}{\alpha^{\lambda,\lambda}}$ : we have drift!

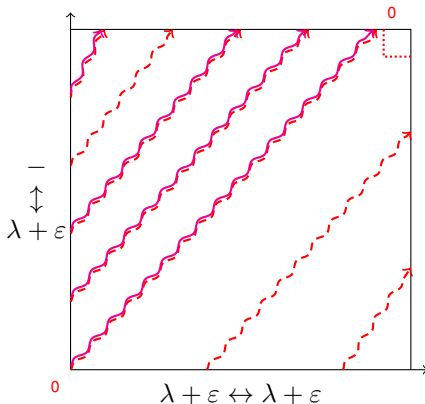

$$\left\{ \frac{\omega^{\lambda+\varepsilon,-}}{\eta^{\lambda+\varepsilon,\lambda+\varepsilon}} \right\} \subseteq \left\{ \frac{\omega^{\lambda+\varepsilon,-}}{\alpha^{\lambda,\lambda}} \right\}$$

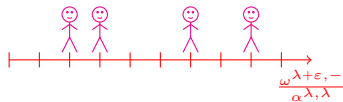

↪: prob. 1

↪: prob.  $t$

↪ rightmost  $\frac{\omega^{\lambda+\varepsilon,-}}{\eta^{\lambda+\varepsilon,\lambda+\varepsilon}}$  second class still left of the small box whp.

$$\theta^{-,-} \leq \frac{\omega^{\lambda+\varepsilon,-}}{\eta^{\lambda+\varepsilon,\lambda+\varepsilon}} \geq \alpha^{\lambda,\lambda}$$

3.  $\frac{\omega^{\lambda+\varepsilon,-}}{\eta^{\lambda+\varepsilon,\lambda+\varepsilon}}$  on  $\frac{\omega^{\lambda+\varepsilon,-}}{\alpha^{\lambda,\lambda}}$ : we have drift!

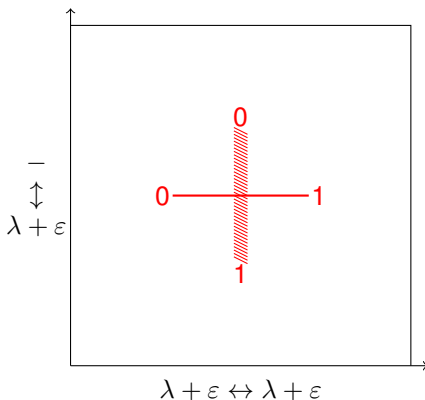

$$\left\{ \frac{\omega^{\lambda+\varepsilon,-}}{\eta^{\lambda+\varepsilon,\lambda+\varepsilon}} \right\} \subseteq \left\{ \frac{\omega^{\lambda+\varepsilon,-}}{\alpha^{\lambda,\lambda}} \right\}$$

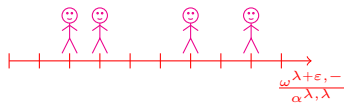

↶: prob. 1

↷: prob.  $t$

↷ rightmost  $\frac{\omega^{\lambda+\varepsilon,-}}{\eta^{\lambda+\varepsilon,\lambda+\varepsilon}}$  second class still left of the small box whp.

$$\theta^{-,-} \leq \frac{\omega^{\lambda+\varepsilon,-}}{\eta^{\lambda+\varepsilon,\lambda+\varepsilon}} \geq \alpha^{\lambda,\lambda}$$

3.  $\frac{\omega^{\lambda+\varepsilon,-}}{\eta^{\lambda+\varepsilon,\lambda+\varepsilon}}$  on  $\frac{\omega^{\lambda+\varepsilon,-}}{\alpha^{\lambda,\lambda}}$ : we have drift!

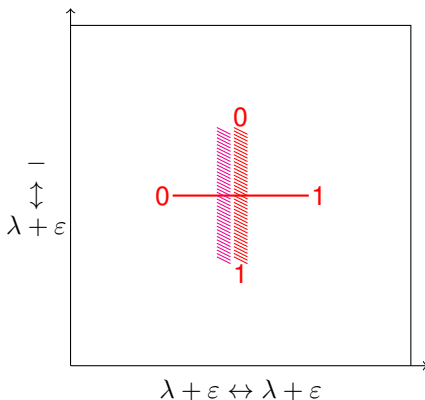

$$\left\{ \frac{\omega^{\lambda+\varepsilon,-}}{\eta^{\lambda+\varepsilon,\lambda+\varepsilon}} \right\} \subseteq \left\{ \frac{\omega^{\lambda+\varepsilon,-}}{\alpha^{\lambda,\lambda}} \right\}$$

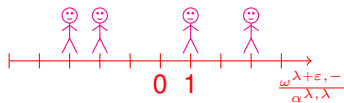

↶: prob. 1

↷: prob.  $t$

↷ rightmost  $\frac{\omega^{\lambda+\varepsilon,-}}{\eta^{\lambda+\varepsilon,\lambda+\varepsilon}}$  second class still left of the small box whp.

$$\theta^{-,-} \leq \frac{\omega^{\lambda+\varepsilon,-}}{\eta^{\lambda+\varepsilon,\lambda+\varepsilon}} \geq \alpha^{\lambda,\lambda}$$

3.  $\frac{\omega^{\lambda+\varepsilon,-}}{\eta^{\lambda+\varepsilon,\lambda+\varepsilon}}$  on  $\frac{\omega^{\lambda+\varepsilon,-}}{\alpha^{\lambda,\lambda}}$ : we have drift!

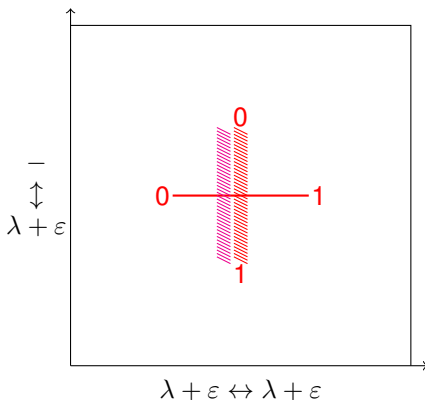

$$\left\{ \frac{\omega^{\lambda+\varepsilon,-}}{\eta^{\lambda+\varepsilon,\lambda+\varepsilon}} \right\} \subseteq \left\{ \frac{\omega^{\lambda+\varepsilon,-}}{\alpha^{\lambda,\lambda}} \right\}$$

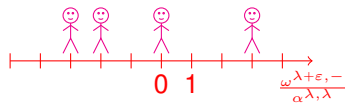

↶: prob. 1

↷: prob.  $t$

↷ rightmost  $\frac{\omega^{\lambda+\varepsilon,-}}{\eta^{\lambda+\varepsilon,\lambda+\varepsilon}}$  second class still left of the small box whp.

---

$$\theta^{-,-} \leq \frac{\omega^{\lambda+\varepsilon,-}}{\eta^{\lambda+\varepsilon,\lambda+\varepsilon}} \geq \alpha^{\lambda,\lambda}$$

3.  $\frac{\omega^{\lambda+\varepsilon,-}}{\eta^{\lambda+\varepsilon,\lambda+\varepsilon}}$  on  $\frac{\omega^{\lambda+\varepsilon,-}}{\alpha^{\lambda,\lambda}}$ : we have drift!

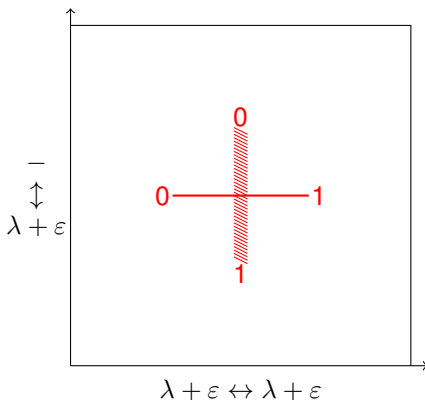

$$\left\{ \frac{\omega^{\lambda+\varepsilon,-}}{\eta^{\lambda+\varepsilon,\lambda+\varepsilon}} \right\} \subseteq \left\{ \frac{\omega^{\lambda+\varepsilon,-}}{\alpha^{\lambda,\lambda}} \right\}$$



↶: prob. 1

↷: prob.  $t$

↷ rightmost  $\frac{\omega^{\lambda+\varepsilon,-}}{\eta^{\lambda+\varepsilon,\lambda+\varepsilon}}$  second class still left of the small box whp.

$$\theta^{-,-} \leq \frac{\omega^{\lambda+\varepsilon,-}}{\eta^{\lambda+\varepsilon,\lambda+\varepsilon}} \geq \alpha^{\lambda,\lambda}$$

3.  $\frac{\omega^{\lambda+\varepsilon,-}}{\eta^{\lambda+\varepsilon,\lambda+\varepsilon}}$  on  $\frac{\omega^{\lambda+\varepsilon,-}}{\alpha^{\lambda,\lambda}}$ : we have drift!

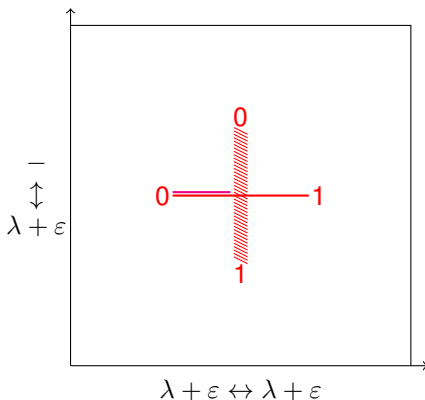

$$\left\{ \frac{\omega^{\lambda+\varepsilon,-}}{\eta^{\lambda+\varepsilon,\lambda+\varepsilon}} \right\} \subseteq \left\{ \frac{\omega^{\lambda+\varepsilon,-}}{\alpha^{\lambda,\lambda}} \right\}$$

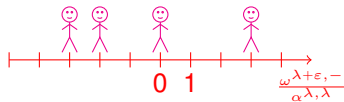

↶: prob. 1

↷: prob.  $t$

↷ rightmost  $\frac{\omega^{\lambda+\varepsilon,-}}{\eta^{\lambda+\varepsilon,\lambda+\varepsilon}}$  second class still left of the small box whp.

$$\theta^{-,-} \leq \frac{\omega^{\lambda+\varepsilon,-}}{\eta^{\lambda+\varepsilon,\lambda+\varepsilon}} \geq \alpha^{\lambda,\lambda}$$

3.  $\frac{\omega^{\lambda+\varepsilon,-}}{\eta^{\lambda+\varepsilon,\lambda+\varepsilon}}$  on  $\frac{\omega^{\lambda+\varepsilon,-}}{\alpha^{\lambda,\lambda}}$ : we have drift!

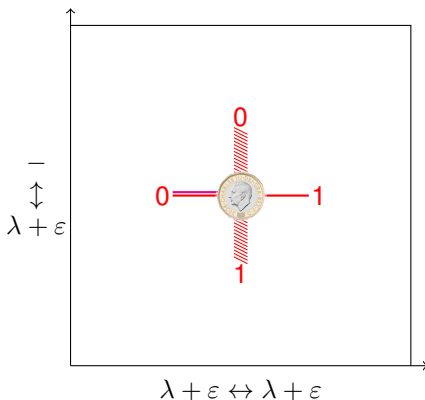

$$\left\{ \frac{\omega^{\lambda+\varepsilon,-}}{\eta^{\lambda+\varepsilon,\lambda+\varepsilon}} \right\} \subseteq \left\{ \frac{\omega^{\lambda+\varepsilon,-}}{\alpha^{\lambda,\lambda}} \right\}$$

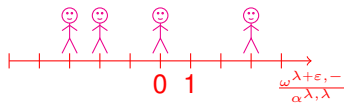

↶: prob. 1

↷: prob.  $t$

↷ rightmost  $\frac{\omega^{\lambda+\varepsilon,-}}{\eta^{\lambda+\varepsilon,\lambda+\varepsilon}}$  second class still left of the small box whp.

$$\theta^{-,-} \leq \frac{\omega^{\lambda+\varepsilon,-}}{\eta^{\lambda+\varepsilon,\lambda+\varepsilon}} \geq \alpha^{\lambda,\lambda}$$

3.  $\frac{\omega^{\lambda+\varepsilon,-}}{\eta^{\lambda+\varepsilon,\lambda+\varepsilon}}$  on  $\frac{\omega^{\lambda+\varepsilon,-}}{\alpha^{\lambda,\lambda}}$ : we have drift!

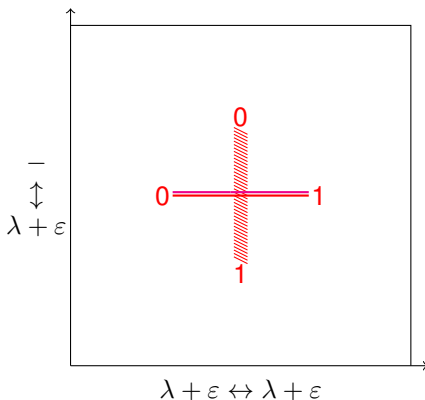

$$\left\{ \frac{\omega^{\lambda+\varepsilon,-}}{\eta^{\lambda+\varepsilon,\lambda+\varepsilon}} \right\} \subseteq \left\{ \frac{\omega^{\lambda+\varepsilon,-}}{\alpha^{\lambda,\lambda}} \right\}$$

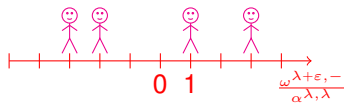

$\curvearrowright$ : prob. 1

$\curvearrowright$ : prob.  $t$

$\rightsquigarrow$  rightmost  $\frac{\omega^{\lambda+\varepsilon,-}}{\eta^{\lambda+\varepsilon,\lambda+\varepsilon}}$  second class still left of the small box whp.

$$\theta^{-,-} \leq \frac{\omega^{\lambda+\varepsilon,-}}{\eta^{\lambda+\varepsilon,\lambda+\varepsilon}} \geq \alpha^{\lambda,\lambda}$$

3.  $\frac{\omega^{\lambda+\varepsilon,-}}{\eta^{\lambda+\varepsilon,\lambda+\varepsilon}}$  on  $\frac{\omega^{\lambda+\varepsilon,-}}{\alpha^{\lambda,\lambda}}$ : we have drift!

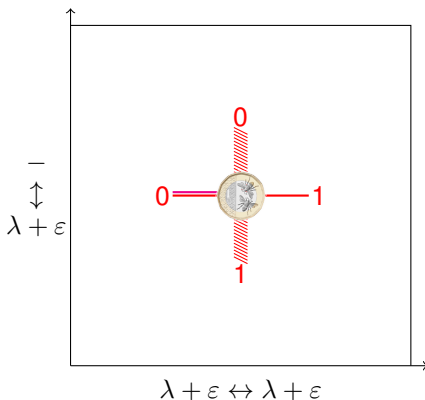

$$\left\{ \frac{\omega^{\lambda+\varepsilon,-}}{\eta^{\lambda+\varepsilon,\lambda+\varepsilon}} \right\} \subseteq \left\{ \frac{\omega^{\lambda+\varepsilon,-}}{\alpha^{\lambda,\lambda}} \right\}$$

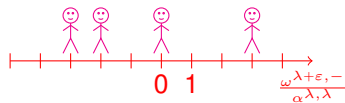

↶: prob. 1

↷: prob.  $t$

↷ rightmost  $\frac{\omega^{\lambda+\varepsilon,-}}{\eta^{\lambda+\varepsilon,\lambda+\varepsilon}}$  second class still left of the small box whp.

$$\theta^{-,-} \leq \frac{\omega^{\lambda+\varepsilon,-}}{\eta^{\lambda+\varepsilon,\lambda+\varepsilon}} \geq \alpha^{\lambda,\lambda}$$

3.  $\frac{\omega^{\lambda+\varepsilon,-}}{\eta^{\lambda+\varepsilon,\lambda+\varepsilon}}$  on  $\frac{\omega^{\lambda+\varepsilon,-}}{\alpha^{\lambda,\lambda}}$ : we have drift!

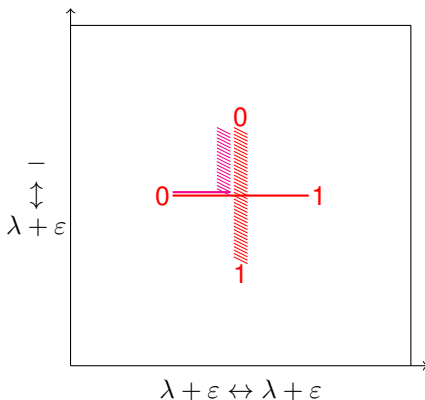

$$\left\{ \frac{\omega^{\lambda+\varepsilon,-}}{\eta^{\lambda+\varepsilon,\lambda+\varepsilon}} \right\} \subseteq \left\{ \frac{\omega^{\lambda+\varepsilon,-}}{\alpha^{\lambda,\lambda}} \right\}$$

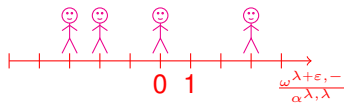

↶: prob. 1

↷: prob.  $t$

↷ rightmost  $\frac{\omega^{\lambda+\varepsilon,-}}{\eta^{\lambda+\varepsilon,\lambda+\varepsilon}}$  second class still left of the small box whp.

$$\theta^{-,-} \leq \frac{\omega^{\lambda+\varepsilon,-}}{\eta^{\lambda+\varepsilon,\lambda+\varepsilon}} \geq \alpha^{\lambda,\lambda}$$

## 4. Conclusion

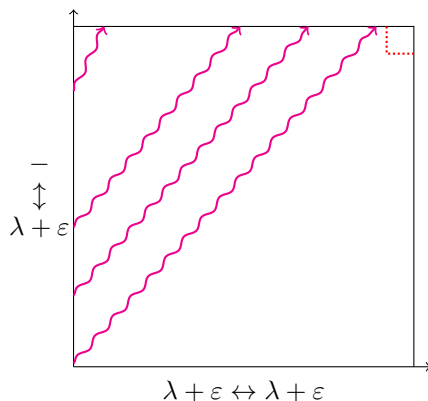

Rightmost  $\frac{\omega^{\lambda+\varepsilon,-}}{\eta^{\lambda+\varepsilon,\lambda+\varepsilon}}$  second class still left of the small box whp.

---

$$\theta^{-,-} \leq \underline{\omega^{\lambda+\varepsilon,-}} \geq \underline{\eta^{\lambda+\varepsilon,\lambda+\varepsilon}} \geq \alpha^{\lambda,\lambda}$$

## 4. Conclusion

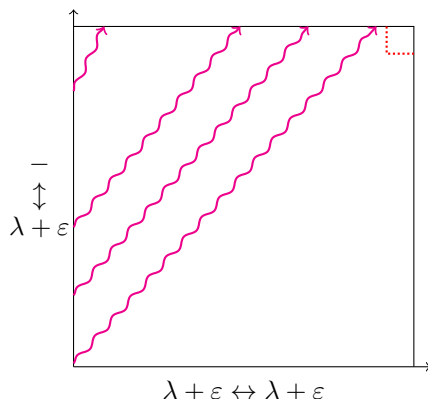

Rightmost  $\frac{\omega^{\lambda+\varepsilon,-}}{\eta^{\lambda+\varepsilon,\lambda+\varepsilon}}$  second class still left of the small box whp.

$\rightsquigarrow \omega^{\lambda+\varepsilon,-} = \eta^{\lambda+\varepsilon,\lambda+\varepsilon}$  in the small box whp.

---

$$\theta^{-,-} \leq \underline{\omega^{\lambda+\varepsilon,-}} \geq \underline{\eta^{\lambda+\varepsilon,\lambda+\varepsilon}} \geq \alpha^{\lambda,\lambda}$$

## 4. Conclusion

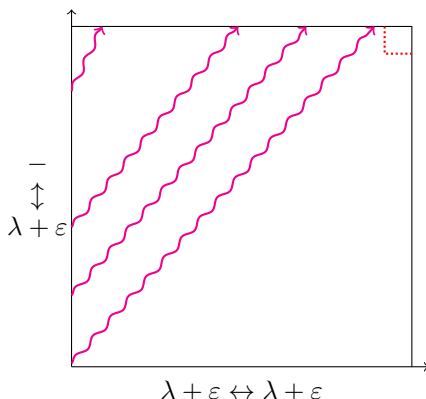

Rightmost  $\frac{\omega^{\lambda+\varepsilon,-}}{\eta^{\lambda+\varepsilon,\lambda+\varepsilon}}$  second class still left of the small box whp.

$\rightsquigarrow \omega^{\lambda+\varepsilon,-} = \eta^{\lambda+\varepsilon,\lambda+\varepsilon}$  in the small box whp.

$\rightsquigarrow$  but  $\eta^{\lambda+\varepsilon,\lambda+\varepsilon}$  is stationary so has  $\text{Poi}(\lambda + \varepsilon)$  lines entering the box whp.

---

$$\theta^{-,-} \leq \underline{\omega^{\lambda+\varepsilon,-}} \geq \underline{\eta^{\lambda+\varepsilon,\lambda+\varepsilon}} \geq \alpha^{\lambda,\lambda}$$

## 4. Conclusion

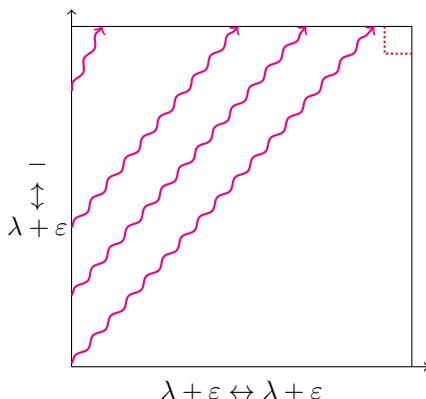

Rightmost  $\frac{\omega^{\lambda+\varepsilon,-}}{\eta^{\lambda+\varepsilon,\lambda+\varepsilon}}$  second class still left of the small box whp.

$\rightsquigarrow \omega^{\lambda+\varepsilon,-} = \eta^{\lambda+\varepsilon,\lambda+\varepsilon}$  in the small box whp.

$\rightsquigarrow$  but  $\eta^{\lambda+\varepsilon,\lambda+\varepsilon}$  is stationary so has  $\text{Poi}(\lambda + \varepsilon)$  lines entering the box whp.

$\rightsquigarrow$  whp.  $\theta^{-,-} \leq \text{Poi}(\lambda + \varepsilon)$   
 $\forall \varepsilon > 0$ .

---

$$\theta^{-,-} \leq \underline{\omega^{\lambda+\varepsilon,-}} \geq \underline{\eta^{\lambda+\varepsilon,\lambda+\varepsilon}} \geq \alpha^{\lambda,\lambda}$$

## 4. Conclusion

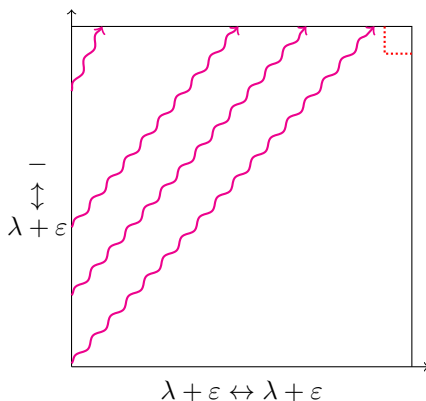

*Thank you.*

Rightmost  $\frac{\omega^{\lambda+\varepsilon,-}}{\eta^{\lambda+\varepsilon,\lambda+\varepsilon}}$  second class still left of the small box whp.

$\rightsquigarrow \omega^{\lambda+\varepsilon,-} = \eta^{\lambda+\varepsilon,\lambda+\varepsilon}$  in the small box whp.

$\rightsquigarrow$  but  $\eta^{\lambda+\varepsilon,\lambda+\varepsilon}$  is stationary so has  $\text{Poi}(\lambda + \varepsilon)$  lines entering the box whp.

$\rightsquigarrow$  whp.  $\theta^{-,-} \leq \text{Poi}(\lambda + \varepsilon)$   
 $\forall \varepsilon > 0.$

---

$$\theta^{-,-} \leq \underline{\omega^{\lambda+\varepsilon,-}} \geq \underline{\eta^{\lambda+\varepsilon,\lambda+\varepsilon}} \geq \alpha^{\lambda,\lambda}$$